

A serene sunset scene over a body of water. The sun is low on the horizon, creating a warm, golden glow that reflects on the water's surface. A small, dark boat is visible in the lower center of the frame. In the background, a large tree stands on the shore, its silhouette partially illuminated by the setting sun. The overall atmosphere is peaceful and tranquil.

2010 MASTERCRAFT OWNER'S MANUAL

Congratulations on your boating choice! MasterCraft is the recognized world leader for inboard boats today and has been for over forty (40) years. The quality, innovation, selection and value of MasterCraft boats are unmatched in the industry.

Please take a few minutes to read this Owner's Manual completely in addition to carefully reviewing any additional information provided in the accompanying packet. These publications will help to answer most of the remaining questions you may have regarding the new boat. If you have any additional questions after reading these items publications, please feel free to speak with your dealer. MasterCraft wants you to feel comfortable with your boat (and trailer, where applicable) from the very beginning of your experience as an owner of our products.

All information in this Owner's Manual is based on the latest product information available at the time of printing. Because of our policy of continuous product improvement, we reserve the right to make changes at any time, without notice, in specifications and models, and also to discontinue models. We also

reserve the right to change specifications, parts or accessories at any time without incurring any obligation to equip the same on models manufactured before the date of the change. MasterCraft recommends checking www.mastercraft.com periodically, specifically the Knowledge Center, for updates and additional information.

Due to changes in specifications, models, parts and/or accessories that may occur after publication of this Owner's Manual, the Owner's Manual may not cover every circumstance that may arise in owning and operating a boat. Also, the illustrations used in this Owner's Manual are intended only as representative reference views and may not depict actual model component parts. Information regarding certain on-board components furnished by suppliers other than MasterCraft, including the engine and power train components, is provided separately by the manufacturers of those components. This information is available through your dealer. A reasonable effort has been made by MasterCraft and its suppliers to provide the applicable information required to ensure a long-lasting and enjoyable boating experience.



WELCOME ABOARD

DANGERS, WARNINGS AND CAUTIONS

Throughout this manual the terms “Danger,” “Warning,” and “Caution” appear, alerting the boat owner and/or operator to dangerous or potentially dangerous situations that may arise. Those terms have the following respective meanings whenever they appear herein:



This is the safety alert symbol. It is used to alert you to potential personal injury hazards. Obey all safety messages that follow this symbol to avoid possible injury or death.



DANGER indicates an imminently hazardous situation which, if not avoided, will result in death or serious injury.



WARNING indicates a potentially hazardous situation which, if not avoided, could result in death or serious injury.



CAUTION indicates a potentially hazardous situation which, if not avoided, may result in minor or moderate injury.



CAUTION used without the safety alert symbol indicates a potentially hazardous situation which, if not avoided, may result in property damage.

Failure to adhere to and comply with the safety dangers, warnings and cautions that appear in this manual can lead to serious illness, injury or even death and/or damage to your boat or the property of others. Beyond these warnings, boaters have a personal responsibility to utilize a common sense approach to the boating experience, including keeping individuals off or near the swim platform and the stern area of the boat during the engine operation. Personal flotation devices (“PFDs”) save lives and ensure positive experiences. **MasterCraft offers many proactive approaches to the boating experience, but the consumer is ultimately responsible for the positive and safe involvement in boating.**

Be sure to review the *Boating Safety* section of this manual, which immediately follows this section. Because of the importance of these dangers, warnings and cautions, they are reprinted here, along with

the pages on which you will find them. Please note that the safety information statements presented below are categorized for information purposes only, and are not presented in any particular order of importance. Each of the statements referenced below and in the other sections of this manual provide you with important safety-related information and must be read and followed to avoid injury or damage, as applicable. We strongly encourage you to cross-reference and read the dangers, warnings and cautions within the context in which they are presented by reading and reviewing those sections.



Failure to comply with safety-related information and instructions may result in serious injury or death to you and/or others. Always use common sense when operating the boat or participating in any activities associated with the boat, including, but not limited to, periods of time when the boat engine is shut down and the boat is not in operation. (Page 1-4)

Following the activation of the automatic fire suppression system or a hand-held fire extinguisher, a careful determination should be made as to whether the boat can safely be operated. If there is any doubt or concern whatsoever, the boat should be towed to shore and/or doc for service by an authorized MasterCraft dealer prior to operating again. Failure to follow these instructions could result in death or serious injury/illness. (Pages 1-2, 1-3)

Opening an engine compartment when there is indication of a fire inside can cause the fire to flare up and/or spread, which may result in extensive damage or even sinking of the boat and/or serious injury or death to people on board. (Page 1-3)

Gasoline is highly flammable and its vapors may ignite, resulting in fire or explosion. Be sure to keep all sparks and flames away from the area while inspecting the boat’s fuel system. (Page 17-2)

Gasoline is explosive. If a gasoline odor is present or gasoline is visually observed in the bilge area during inspection, **DO NOT START YOUR ENGINE!** Remove the ignition key from the ignition switch and call an authorized MasterCraft dealer for service. (Pages 7-1, 17-6)

Gasoline is extremely flammable and highly explosive under certain conditions. Always stop the engine and never smoke or allow open flames or sparks within fifty (50) feet of the fueling area when fueling. (Page 7-1)

Take care not to spill gasoline. If gasoline is spilled accidentally, wipe up all traces of it with dry rags immediately and dispose of properly on shore. (Page 7-1)

To prevent a possible explosion, operate the blower for at least four (4) minutes before starting the engine and always when at idle or slow-running speed. Explosive gasoline and/or battery fumes may be present in the engine compartment. Failure to do so may result in serious injury or death! (Page 10-1)

To prevent a possible explosion, operate the blower for at least four (4) minutes before starting the engine and always when at idle or slow-running speed. Explosive gasoline and/or battery fumes may be present in the engine compartment. Failure to operate the blower

as instructed may cause improper ventilation of the boat engine and bilge areas, and fuel vapors can accumulate in this area, causing a fire or explosion which may result in death or serious injury! (Page 5-3)

Carbon monoxide is a colorless, tasteless, odorless and poisonous gas that accumulates rapidly and can cause serious injury or death. Exposure to carbon monoxide can be fatal in a matter of minutes. Exposure to even low concentrations of carbon monoxide must not be ignored because the effects of exposure to carbon monoxide can build up and be just as lethal as high concentrations. Carbon monoxide from exhaust pipes of inboard or outboard engines may build up inside and outside the boat in areas near exhaust vents, particularly during slow-speed operations. **STAY AWAY** from these exhaust vent areas, which are located at the stern of the boat, and **DO NOT** swim or engage in any watersports or other activities in or near the stern area of the boat, including, without limitation, the swim platform and the rear sun deck, when the engine is in operation. Under no circumstances should the owner and/or operator allow persons to hold onto the swim platform while the engine is operating and the boat is in motion. These activities (sometimes known as “teak surfing” or “platform dragging,” where the participant holds onto the swim platform and is pulled through the water, and/or “body surfs” immediately behind the boat) are extremely dangerous, highly likely to result in death or serious bodily injury, and are a misuse of this product. (Page 2-1, 6-6)

The safety switch lanyard must be attached to the operator whenever the engine is running. Failure to do so may result in death or serious injury! (Page 5-4)

Never override or modify the engine emergency safety shut-off switch in any way. (Page 1-5)

Before starting the engine, open the engine compartment and check for gasoline fumes, fuel and oil leaks or the presence of fuel or oil in the bilge. (Page 10-1)

Do not tow more than two (2) persons at one time on a tow tower. The tow tower approved for use on your boat should be used only for water skis, wakeboards or recreational towables, and not for parasailing, kite flying or towing other boats. Do not add any attachments that are not approved for use on your MasterCraft boat. Do not climb on, sit on, stand on, jump off of or dive off of the tower. Never allow passengers to sit behind the tow rope attachment point. Never allow loose tow rope ends to dangle. Always be certain that all bolts are in place and tight before and during use. When the tower is up, watch for low obstacles such as tree limbs, bridges or power lines. (Page 1-5)

Information regarding the maximum number of people and/or additional weight to the boat is included in the Guide to Individual Models section of this Manual. It is the boat operator’s responsibility to ensure that the boat is never overloaded. Too much additional weight may cause the boat to overturn or sink, which can result in serious bodily injury or death. (Page 11-1)

Boat operators should never attempt to duplicate operational skills of professional drivers. When such maneuvers fail, it can result in serious injury or death. (Page 11-2)

Failure to comply with the requirement of operating the blower for at least four (4) minutes before starting the engine may result in serious injury or death to you and/or others. (Page 1-5)

Carbon monoxide is emitted from the engine’s exhaust system. Never run the engine without proper ventilation. Do not run the engine in a confined space or where fumes may be trapped. Do not run the engine when the boat is stationary in calm wind conditions. (Page 5-6)



Carbon monoxide is emitted from the engine’s exhaust system. Never run the engine without proper ventilation. Do not run the engine in a confined space or where fumes may be trapped. (Pages 6-4, 6-5)



DO NOT launch or operate the boat if any problem is found during the Safety Check. A problem could lead to an accident during the outing, resulting in death or serious injury. Any and all problems should receive attention immediately. See your authorized MasterCraft dealer’s service department for assistance. (Page 8-1)

Battery electrolyte fluid is dangerous. It contains sulfuric acid, which is poisonous, corrosive and caustic. If electrolyte fluid is spilled or placed on any part of the human body, immediately flush the area with large amounts of clean water and immediately seek medical attention. (Page 17-1)

When charging, batteries generate small amounts of dangerous hydrogen gas. This gas is highly explosive. Keep all sparks, flames and smoking well away from the area. Failure to follow instructions when charging a battery may cause an electrical charge or even an explosion of the battery, which could result in death or serious injury. (Pages 6-1, 17-1, 17-3)

The engine box serves as a machinery guard. The engine must be **OFF** whenever the box is open. Clothing or body parts can get caught in moving parts, causing death or serious injury. Keep away from moving parts! (Pages 5-4, 17-2, 17-3, 17-4)

Adding additional ballast to a MasterCraft boat is not recommended, and can result in impaired visibility, diminished handling characteristics and instability when operating your boat, and may result in potential structural and/or engine damage to the boat, which damage will not be covered by your warranty. (Page 11-1)

Use of improper parts may cause component or engine failure. Such failure may result in death or serious injury! (Page 13-1)

All boats have weight limits. Failure to adhere to the posted limits can cause operation instability and/or the boat to sink. This may result in serious injury or death, as well as significant damage to the boat, which will not be covered by warranty. (Page 2-1)

While operating attitude adjustment plates use caution. Improper use of plates can cause accidents, which may result in serious injury or death.

While the boat is underway do not move one plate up or down significantly as this may cause listing.

While at higher speeds do not over-trim, as this will cause the bow to lower quickly, resulting in a reduction of speed and may cause the boat to veer.

When in following seas or when running an inlet, the plates should be fully retracted. This will allow for optimal performance.

ELECTRO-MECHANICAL ACTUATORS PROVIDE AN INSTANT RESPONSE. WHEN MAKING ADJUSTMENTS, USE SHORT MOMENTARY TAPS OF THE SWITCH. (Page 5-2)

Improperly stored anchors and/or anchor line that has been improperly re-wound through the windlass system, may create a hazardous situation. People on-board can trip on improperly stored materials, which can result in injury. Improperly stored materials can also move too freely during boat operation and make contact with individuals, again causing injury. Properly store all anchor and lines whether the boat is in operation or not, unless the anchor and line are in use. (Page 6-1)

The platform must be raised and locked into position for use of the platform while boating. No one should be allowed on the platform until the platform is securely locked in place and the engine is OFF. Failure to do so may result in serious injury or death! (Page 6-7)

MasterCraft has determined that for the tower utilized on the current models, the total weight of all accessories mounted on the tower should never exceed 85 pounds, regardless of whether the accessories are MasterCraft-approved and supplied or have come from an aftermarket supplier. Exceeding this restriction can result in tower failure, which could result in serious injury or death to the boat operator and/or passengers. (Page 6-7)

Engaging the engine synchronization functionality requires practice to master. Because the boat will be in gear and will move during the process, even after mastering the maneuver boat operators should synchronize engines only on bodies of water of sufficient size to accomplish the maneuver without making contact with other vessels or with inanimate objects, which could cause serious bodily injury or significant damage to the boat. (Page 5-4)



Be sure all fasteners used are approved and rated for marine use. Most fasteners used on MasterCraft boats are stainless steel or specially coated to resist corrosion. (Page 13-1)

All replaced fuel components must meet United States Coast Guard ("USCG") and American Boat & Yacht Council, Inc. ("ABYC") standards, and must be Underwriter's Laboratory ("UL")-approved. Inferior quality components pose a serious safety threat to you and others, and the use of inferior components may result in serious injury or death. Resulting damage may void the warranty. (Page 17-6)

Do not continue to run the engine if the oil pressure is low. If you do, the engine may become so hot that it, or surrounding components, could catch fire. You or others could be burned and the boat seriously damaged. Check your oil level and add an appropriate amount of approved motor oil before operating again or have your boat serviced by your local authorized dealer's service department. Note that damage to your engine from inappropriate oil levels can be costly to repair. Such damage is not covered by your warranty. (Page 5-4)

Some engine parts become very hot during operation. This inspection must be completed while the engine is cool to prevent burns to your skin. Perform this task before starting the boat. (Pages 17-2, 17-5)



When boating, avoid using the windshield as an aid for balance or getting out of a seat. This causes undue stress to the window frame and could damage it, which may not be covered under warranty. (Page 8-1)

To ensure proper break-in and lubrication, boat owners should not remove the factory break-in oil until after the initial ten (10) hours of operation. At that time, an oil change should be performed on the Indmar engines by an authorized MasterCraft service technician at an authorized MasterCraft dealer. (Page 9-1)

DO NOT use the ski pylon or any portion of any tower for lifting. They are **NOT** designed to be used as a central lifting point. Also, **DO NOT** use the stern ski tow as a lifting ring. The deck may be damaged. See the *Storage Cradle* sub-section of this section. Also never lift a boat with water in the bilge or containing a water-filled device such as a ballast system or sack. The extra stress will put an excessive load on the hull and lifting equipment that may seriously damage the boat. Such damage may not be covered by the warranty. (Page 12-1)

Continued operation after the warning light has illuminated may cause severe engine damage. This will void your warranty. (Page 10-2)

Because of the complexity of preparing a boat for proper winter storage, as well as the possibility of extreme damage to the drive train if a preparation error was made during winterization, MasterCraft recommends scheduling an appointment with an authorized MasterCraft dealer's service department to permit a technician to perform all winterization procedures. (Page 18-1)



Add-on equipment may adversely affect the alternator output or overload the electrical system. Such damage may not be covered by the warranty. (Page 17-1)

Failure to follow the engine oil recommendations listed in the engine manual can cause additional engine wear and increase the possibility of engine component failure. Damage to the engine due to incorrect oil usage can be costly to repair, and is not covered by the warranty! (Page 9-1)

Do not operate the starter motor continuously for more than fifteen (15) seconds without at least two (2) minutes for a “cool-down” period. Failure to do so may cause the starter to overheat, resulting in damage. Failure to release the ignition key after the engine has started may cause damage to the starter motor and drive. (Page 10-1)

Allowing the fuel level in the fuel tank to fall below one-quarter of a tank full may affect the reliability of the fuel pump or result in damage to the fuel pump, which is not covered under warranty. (Pages 5-6, 7-1)

Damage to the engine by use of low-quality gasoline or gasoline with an octane rating below the minimum level listed will void the warranty on the boat. (Page 7-1)

Fuels that are blended to contain methanol or wood alcohol should not be used. These fuels can corrode metal parts in the fuel system and engine. Fuels that contain methanol will damage the engine. Damage caused by the use of unapproved fuels is not covered by warranty. (Page 7-2)

Extended storage with fuel in the system can affect the fuel's stability and may require system inspection and fuel filter replacement when the unit is placed back into service. (Page 7-2)

Lifting slings must never contact shafts, struts or hardware protruding from the hull. Damage may result that would void the warranty. (Page 12-1)

When the boat is out of the water, it is important to support the hull correctly to avoid any hull damage. Such damage may void the warranty. (Page 12-1)

Crossing cables or jumper cables may result in damage to the electrical components due to incorrect battery connections. Such damages may not be covered by your warranty. (Page 17-3)

Attention must be paid to any leakage occurring in the propeller shaft log area. Water intrusion into the transmission, which can happen if excessive leakage is occurring may cause serious damage. Such damage may not be covered by the warranty. (Page 17-2)

Engines should always be operated within engine manufacturer guidelines. Failure to do so may cause significant damage to the engine and drive train and is not covered under warranty! (Page 11-2)

Continuing to operate the boat while the temperature is above normal operating parameters may cause serious damage to your engine. Damage to your engine resulting from operating the engine in an overheated condition can be costly to repair. Such damage is not covered by your warranty! (Page 5-8)

Exposure to salt water will cause corrosion leading to significant damage to stainless steel and chrome parts. Failure to thoroughly rinse salt water from all hardware, and to apply protective oil after each exposure to salt water, will accelerate the corrosion of hardware and will void your warranty. (Page 13-1)

The anchor, sometimes accompanied by a windlass, has been provided to assist boaters in remaining in a chosen location. Note that use of the anchor system will not guarantee a properly anchored boat or that the boat will remain in a stationary position. Environmental, bottom conditions, current and tidal conditions must be taken into consideration when anchoring the boat. Only properly trained operators should set the anchor for this system. Establishing a secure anchorage requires practice. Damage to your boat may result due to improper anchoring techniques. (Page 6-1)

The platform must be raised and locked into position for transportation of the boat, as well as use of the platform while boating. Leaving the platform down may result in damage to the boat transom during transport that will not be covered by the warranty! (Page 6-6)

TABLE OF CONTENTS

Welcome Aboard.....	i
Dangers, Warnings and Cautions	ii

Safety Knowledge

Boating Safety	1-1
General Precautions	1-1
Safety Equipment	1-1
Required Equipment	1-1
Fire Extinguishers	1-2
Fire Suppression & Extinguishing (All V-Drives).....	1-2
Fire Suppression & Extinguishing (Others).....	1-2
Fire Port	1-3
Personal Flotation Devices (PFDs)	1-3
PFD Accessibility	1-3
Sound Producing Devices	1-3
Visual Distress Signals	1-3
Registration, Numbering and Documentation	1-4
Operator's License	1-4
Recommended Equipment.....	1-4
Safety Afloat	1-4
Skiing and Wakeboarding Safety	1-5
Warning Plates and Labels	1-6
Operator's Responsibilities	1-6
Float Plan	1-6
Nautical Charts.....	1-6
Weather.....	1-6
Staying Afloat.....	1-6
Cold Water Survival	1-6
Hypothermia.....	1-7
Immersion Suits	1-7
Inflatable Life Rafts.....	1-7
Anchoring.....	1-7
Communications.....	1-7
Law Enforcement	1-7

Common Sense Approach	2-1
------------------------------------	-----

Rules of the Open Water	3-1
The General Prudential Rule.....	3-1
Steering and Sailing Rules/Sound Signals.....	3-1
Rules When Encountering Vessels	3-1
Meeting	3-1
Crossing	3-1
Overtaking.....	3-1
Other Special Situations.....	3-2
Sailing Vessel Right-of-Way	3-2
Fishing Vessel Right-of-Way	3-2
Reading Buoys and Other Markings	3-2

Guide to Individual Models

ProStar 190.....	4-1
ProStar 197, X-7	4-2
ProStar 214, X-14.....	4-3
ProStar 214, X-14 V-Drive	4-4
X-1.....	4-5
MariStar 200, X-2.....	4-6
MariStar 215, X-15.....	4-7
MariStar 230, X-30.....	4-8
MariStar 235, X-35.....	4-9
MariStar 245, X-45.....	4-10
MariStar 255, X-55.....	4-11
X-Star.....	4-12
MariStar 280, X-80.....	4-13
CSX 220.....	4-14
CSX 265.....	4-15
Instrument Panels.....	4-16
Measurements	4-17

Instrument Gauges and Switches	5-1
12-Volt Receptacle	5-1
Accessory Switches.....	5-1
Aft Light Switch	5-1
AM/FM Stereo, CD Player, Remote Control iPod and MP3 Player Connections.....	5-1
Attitude Adjustment or Trim Tab Switch	5-1
Ballast Empty/Fill Switches.....	5-2
Manual and Automatic Bilge Pump Switch.....	5-2
Blower Switch	5-3
Circuit Breakers.....	5-3
Courtesy Lights Switch.....	5-3
Cruise Control Gauge	5-3
Display Selector Switch.....	5-3
Dual Battery Operation Switch	5-3
Engine Emergency Safety Stop Switch	5-4





Engine Hatch Switch	5-4
Engine Oil Pressure Gauge.....	5-4
Engine Synchronizing Switch.....	5-4
Fuel Gauge.....	5-5
Heater Switch.....	5-6
Horn.....	5-6
Ignition Key Slot.....	5-6
Instrument Panel Gauge Backlighting Switch.....	5-6
Low Voltage Battery Alarm.....	5-6
Multi-Function Gauge	5-6
Navigation/Anchor Lights Switch	5-7
Other Alarms.....	5-7
Refrigerator Switch.....	5-7
Seat Heat Switches.....	5-7
Shift/Throttle Control.....	5-7
Shower and/or Slick Boot Switch	5-8
Sink Switch	5-8
Speedometer	5-8
Tachometer	5-8
Temperature Gauge	5-8
Tower Lights Switch	5-8
Underwater Lights Switch.....	5-8
Video Display Gauge	5-9
Voltmeter	5-10
Wash Down Switch.....	5-10
Variations in Gauges and Switches.....	5-10

Comfort and Convenience.....	6-1
Anchor and Windlass.....	6-1
Battery Charger	6-1
Canvas Covers	6-2
Coolers	6-2
Fire Suppression and Extinguishing.....	6-2
GPS and Chartplotter.....	6-3
Head.....	6-3
Heater	6-4
Hydraulic Steering System	6-4
Lighting	6-4
Livewell/KillBox/Catch Box.....	6-5
Refrigeration	6-5
Seat Heaters	6-5

Shower or Wash Down	6-5
Stereo Equipment	6-6
Swim/Boarding Platform.....	6-6
Tables.....	6-7
Towers	6-7
Video Screen	6-7
Water Heater.....	6-8

Preparation

Using Care When Fueling	7-1
Indmar Engines	7-1
What Type of Gasoline To Use	7-1
When the Boat Is Not Used for a While	7-2
Using Oxygenated Fuels or Fuels with Alcohol.....	7-2
Fuels Outside the U.S. and Canada	7-2
Volkswagen Diesel Engine.....	7-2

Safety Checks and Services	8-1
Before Each Operation.....	8-1
During Operation	8-1
After Operation.....	8-1

New Boat Break-In.....	9-1
First Hours of Operation	9-1
After Break-In.....	9-1

Starting and Basic Operation.....	10-1
Before Starting.....	10-1
Starting the Engine	10-1
Shifting Gears	10-1
Underway.....	10-2
Stopping.....	10-2

Operational Hints	11-1
Loading.....	11-1
Emergencies	11-1
Courtesy.....	11-1
First Time Operation.....	11-1
Basic Maneuvering	11-1
High Speed Operation	11-2
Unusual Operating Conditions	11-2
Docking and Tie-Up.....	11-3

Care and Maintenance

Lifting the Boat.....	12-1
Using Lifting Eyes	12-1
Using Lifting Slings.....	12-1
Storage Cradle	12-1

Corrosioin Prevention.....	13-1
Galvanic Corrosion.....	13-1
Salt Water Corrosion.....	13-1
Marine Growth.....	13-1
Stainless Steel and Chrome.....	13-1

Cleaning the Boat	14-1
Hull	14-1
Upholstery	14-1
Carpet.....	14-1
Teak Wood	14-1
Fiberglass Swim Platform	14-2
Windshield	14-2
Canvas Covers	14-3
Enclosed Head.....	14-3
Slick Boot.....	14-4
Acceptable Upholstery Cleaners.....	14-4
Unacceptable Upholstery Cleaners	14-4
MasterCraft Boat Care Products	15-1
All Purpose Cleaner.....	15-1
Boat Cleaner & Polish	15-1
Vinyl Dressing.....	15-1
Glass Cleaner	15-1
Bilge Cleaner	15-1
Hull Cleaner	15-1
Spray Wax.....	15-1
Boat Wash & Wax.....	15-1
Microfiber Detailing Cloths.....	15-1
Cleaning & Detailing Kit	15-2
Marine Motor Oil & Filters.....	15-2
Scheduled Maintenance Service	16-1
Frequency and Scheduled Maintenance	16-1
New Boat Break-In	16-1
Before Each Use.....	16-1
After Each Use.....	16-1
Quarterly (Every 50 Hours).....	16-1
Annually (Every 100 Hours).....	16-1
Scheduled Maintenance	17-1
<i>Before Each Use (Prior to Starting the Engine)</i>	17-1
Inspect Seacock Strainer	17-1
Inspect Battery Connections & Hold-Downs	17-1
Inspect Throttle & Shift Cables.....	17-2
Inspect Fuel System for Leaks	17-2
Inspect Exhaust System for Leaks	17-2
Check Battery is Fully Charged.....	17-2
<i>Before Each Use (After Starting the Engine)</i>	
Inspect the Propeller Shaft Log.....	17-3
Inspect Fuel System for Leaks	17-3
Inspect Exhaust System for Leaks	17-3
<i>After Each Use</i>	17-4
General Cleaning and Storage.....	17-4
Inspections	17-4
<i>Quarterly (Every 50 Hours)</i>	17-4
Lubricate Engine Starter Gear & Shaft.....	17-4

<i>Annually (Every 100 Hours)</i>	17-4
Annual Maintenance.....	17-4
Check Engine Mounts.....	17-5
Check Propeller Shaft Coupling Alignment.....	17-5
Inspect Exhaust Flaps for Damage	17-5
Lubricate Steering System.....	17-5
Lubricate Shift & Throttle System.....	17-5
Check Ballast Pump Impeller	17-5
Inspect Complete Fuel System for Leakage.....	17-5
Fire Extinguisher and Suppression Units.....	17-6

Storage and Winterization	18-1
General Preparation	18-1
Fuel System Treatment	18-1
General Power Package Preparation.....	18-1
Other Winterization Preparations.....	18-1
Ballast System Preparations.....	18-2
Re-Activating the Boat After Storage	18-3

Propeller Maintenance	19-1
Checking/Repairing Propellers	19-1
Changing Propellers	19-1

Guide to Troubleshooting	20-1
---------------------------------------	------

Warranty	
Limited Warranty Statement	21-1

Warranty Registration and Transfer	22-1
---	------

Service Log	23-1
--------------------------	------

Index	24-1
--------------------	------



SAFETY KNOWLEDGE



BOATING SAFETY

Your safety, as well as the safety of others with and around you, is a direct result of how you operate and maintain your boat. You—and anyone who will be operating this boat—should read and seek to fully comprehend this Owner's Manual, and any additional information provided by component manufacturers and suppliers. Make sure that you understand all of the controls and operating instructions before attempting to operate the boat. **Improper operation is extremely dangerous!**

The basic safety rules are outlined in this section of the Owner's Manual. Additional precautions throughout the Manual are noted by the following symbols:



This is the safety alert symbol. It is used to alert you to potential personal injury hazards. Obey all safety messages that follow this symbol to avoid possible injury or death.



DANGER indicates an imminently hazardous situation which, if not avoided, will result in death or serious injury.



WARNING indicates a potentially hazardous situation which, if not avoided, could result in death or serious injury.



CAUTION indicates a potentially hazardous situation which, if not avoided, may result in minor or moderate injury.



CAUTION used without the safety alert symbol indicates a potentially hazardous situation which, if not avoided, may result in property damage.

The precautions listed in this Owner's Manual and on the boat are not all-inclusive. If a procedure, method, tool or part is not specifically recommended by MasterCraft, using it may place you and others in an unsafe situation; in addition, you may render your warranty void. Remember: **Always use common sense when operating, servicing or repairing the boat!**

Observing the safety recommendations found in this Owner's Manual is critical to keeping your boating experience as safe as possible during routine operation. Your failure to do so may result in severe personal injury or death to you and/or others. Use caution and common sense when operating your boat. Do not ever take unnecessary chances!

General Precautions

Be certain that all operators of your boat are aware of the safety information within this Owner's Manual and that they use it to conform to boat safety principles.

Boating safety starts with a thorough understanding of boat operations. In addition to careful review of this Owner's Manual, you should also be aware that many sources of helpful information are available. MasterCraft urges you to pursue additional training prior to the independent operation of your boat. However, training at any time from recognized boating and/or safety organizations is beneficial.

The following is a listing of a few agencies and organizations that offer safety training and/or information:

American Red Cross, National HQ
8111 Gatehouse Road, 6th Floor
Falls Church VA 22042
(202) 737-8300
www.redcross.org

U.S.A. Water Ski Association
1251 Holy Cow Road
Polk City FL 33868
(863) 324-4341
www.usawaterski.org

Boat Owners Association of the United States
880 South Pickett Street
Alexandria VA 22304
(703) 823-9550
www.boatus.com

National Safe Boating Council
2550 M Street NW, Suite 425
Washington DC 20037
(202) 296-4588
www.safeboatingcouncil.org

U.S. Coast Guard Auxiliary
2100 Second Street SW
Washington DC 20593-001
(202) 267-1001
www.uscg.mil

Safety Equipment

Federal law requires certain safety equipment to be on-board your boat at all times. Responsible boaters carry additional equipment in case of emergency. It is your responsibility to check with the local boating authorities for any additional requirements and/or equipment over and above the federal requirements.

Required Equipment

Your MasterCraft boat has been equipped at the factory with most of the federally required safety equipment for inland waters (Class II, 26-foot-to-40-foot watercraft). This equipment includes:

- ABYC-approved (American Boat & Yacht Club) marine mufflers with water injection;
- USCG-approved (United States Coast Guard) marine flame arrester;

- USCG-approved engine box ventilation with sparkless power blower;
- ABYC-approved electric horn sound-warning device;
- USCG-approved inland lighting.

Fire Extinguishers

The engine compartment of all V-drive and the CSX 265 models is equipped with an automatic fire suppression system with a manual override that uses a clean agent canister, which is housed in the engine compartment and is integrated with the fire suppression system. The direct drive and CSX 220 models are equipped with a fire port, into which the contents of a clean-agent canister can be released into the engine compartment.

Except as set forth below, you are also required by law to have on board one (1) five-pound, dry chemical fire extinguisher rated for Type A, B and C fires. The law requires that for all boats more than 26 feet in length, which includes the MariStar 280, X-80 and CSX 265 models, you must have on board two (2) five-pound, dry chemical fire extinguishers. The dry chemical fire extinguisher is optional equipment, which is not automatically included in your boat from the factory, but it can be ordered from MasterCraft with your boat and can also be purchased from an authorized MasterCraft dealer.

If any of the fire suppression system canisters on board your boat are discharged (whether a canister in an automatic system or a portable fire extinguisher), then they must be replaced. The automatic fire suppression system available on all V-drive and CSX 265 models has an indicator light at the helm that will be green if the system is fully charged and will be red if the automatic fire suppression system has been discharged. If the clean agent canister associated with the automatic fire suppression system or the clean agent canister used in connection with a fire port has been discharged, then you must contact your authorized MasterCraft dealer to obtain a replacement for the clean agent type of canister. If the dry chemical fire extinguisher has been discharged, then you may purchase a replacement five-pound dry chemical fire extinguisher that is rated for Type A, B and C fires from an authorized MasterCraft dealer or from another source.

Fire extinguishers require periodic maintenance. Monthly, each fire extinguisher on your boat should be examined to be sure that the seals and tamper indicators are not broken or missing. The pressure gauges or indicators, if applicable, should read in the operable range. There should be no obvious physical damage, rust, corrosion, leakage or clogged nozzles. Additionally, if the extinguisher has not been used, it should be weighed annually to assure that the minimum weight as stated on the label still exists. Any fire extinguisher that has been partially emptied must be replaced or taken to a qualified fire extinguisher servicing company for recharging.

Fire Suppression and Extinguishing (All V-Drives)



Automatic Fire Suppression

All MasterCraft V-drives are equipped with an automatic fire suppression system. The automatic system operates from sensors in the engine room and will automatically release a clean-agent, gaseous chemical that does not leave residue behind. In boats sold domestically, this is the FE-241 system; internationally, it is the FM-200 system.

Upper left: FM-200
left: FE-241

It is also possible to activate the system manually. Pull the pin shown in the photo below with the red tag, and then pull the red fire handle to set the system in operation.

In case of an engine compartment fire, shut down the engine and blowers before manual discharge, or immediately following the automatic discharge. Boats are equipped with a discharge indication light at the instrument panel.

After the suppression system has been used, the fire extinguisher canister will be empty. The boat owner/operator should have the canister replaced as soon as practicable.

V-drive boats have also been specified to carry a hand-held 2.5 lb. monoammonium phosphate expellant (dry chemical) unit, which is rated Class A (trash, wood and paper), Class B (UL Approved) and Class C (energized electrical equipment). These units should be used in situations other than engine compartment fires.

The MariStar 280, X-80, and CSX 265 models are specified to have two (2) of the dry chemical, hand-held extinguishers on-board; all other V-drives are specified for one (1) dry chemical, hand-held extinguisher. This is in addition to the suppression system in the engine compartment.

Hand-held units should be replaced or recharged as soon as possible after use. Chemical discharge should be cleaned from all surfaces as soon as possible and prior to running the boat again, unless operation is necessary to return to shore.

The boat should never be operated following a fire until after a determination has been made whether operation may result in another fire. If any danger of an additional fire exists, the boat should be towed to shore or dock rather than running the engine(s).

Consumers who choose to purchase fire control equipment from resources other than MasterCraft must follow the instructions and requirements as listed within the engine compartment regarding suitability for the compartment volume. These standards are established by the ABYC.



Following the activation of the automatic fire suppression system or a hand-held fire extinguisher, a careful determination should be made as to whether the boat can safely be operated. If there is any doubt or concern whatsoever, the boat should be towed to shore and/or dock for service by an authorized MasterCraft dealer prior to operating again. Failure to follow these instructions could result in death or serious injury/illness.

Fire Suppression and Extinguishing (ProStar 190, ProStar 197, X-7, ProStar 214 direct drive, X-14 direct drive, 220 CSX)

These models are specified for two (2) fire extinguishers, both to be held in the void beneath the observer's seat or under the helm on the 220 CSX. One unit is a hand-held 2.5 lb. monoammonium phosphate expellant (dry chemical) unit, which shall be rated Class A (trash, wood and paper), Class B (UL Approved) and Class C (energized electrical equipment). These units should be used in fighting all on-board fires other than engine compartment fires.



Hand-held units (white bottle shown left) should be replaced or re-charged as soon as possible after use, or after 12 years from date of manufacture. Any chemical discharge should be cleaned from all surfaces as soon as possible and prior to running the boat again, unless operation is necessary to return to shore.



The other specified unit is a hand-held fire suppression unit FM-200 (international boats) or FE-241 (domestic boats). The difference from V-drive models is that the unit is not mounted in the engine compartment, and it must be manually operated (red bottle shown above right).

In the event of any evidence of a fire within the engine compartment, **DO NOT OPEN THE ENGINE COMPARTMENT (BOX).**



Opening an engine compartment when there is indication of a fire inside can cause the fire to flare up and/or spread, which may result in extensive damage or even sinking of the boat and/or serious injury or death to people on board.

Shut down the engine and blowers. Continuously discharge the entire contents of the FM-200 or FE-241 fire suppression unit through the fire port immediately.

Fire Port

On these models, the engine compartment is equipped with a fire port on the side of the engine box. In the event of a fire, insert the nozzle of the fire extinguisher through the fire port pull the safety pin and press the handle to release the clean-agent, gaseous chemicals inside the engine box.

The boat owner/operator should have the fire extinguisher canister replaced as soon as practicable.

The boat should never be operated following a fire until after a determination has been made whether operation may result in another fire. If any danger of an additional fire exists, the boat should be towed to shore or dock rather than running the engine(s).



Following the activation of the automatic fire suppression system or a hand-held fire extinguisher, a careful determination should be made as to whether the boat can safely be operated. If there is any doubt or concern whatsoever, the boat should be towed to shore and/or dock for service by an authorized MasterCraft dealer prior to operating again. Failure to follow these instructions could result in death or serious injury/illness.

Personal Flotation Devices (PFDs)

Federal law also requires at least one wearable Type I, II, III or Type V Personal Flotation Device ("PFD"), for each person on-board or being towed on water skis, wakeboards or other recreational equipment. A Type V PFD provides performance of either a Type I, II or III PFD (as marked on its label) and must be used according to the label requirements. In addition, one throwable Type IV PFD must also be on board. **As the owner, obtaining the appropriate PFDs is your responsibility and determining whether people on-board, including those who are underage, are required to wear PFDs when underway.** Your MasterCraft dealer can, and will be happy to, assist you with your purchase of appropriate PFDs.

Note: Requirements for coastal waters and inland waters differ. Check with the local boating authorities for more information.

PFD Accessibility

- Wearable PFDs must be readily accessible in the boat.
- It should be possible to put on the PFDs within a reasonable amount of time in case of emergency.
- PFDs should never be stowed in plastic bags, in locked or closed compartments or have other gear stowed on top of them.
- The U.S. Coast Guard, as well as MasterCraft, recommends the wearing of PFDs at all times when the vessel is underway, even though it is not a requirement. The best PFD is the one that is worn—that is, the one that can save your life.
- Inflatable PFDs must have a full cylinder and all status indicators on the inflator must be green, or the device is NOT serviceable, and is NOT considered a usable PFD for anyone on-board the vessel.
- Coast Guard-approved inflatable PFDs are authorized for use on recreational boats by persons at least 16 years of age.
- Some states require children to wear PFDs at all times. Check with your state boating safety officials for details. Be certain to equip children with a PFD that is appropriate for the size of the child. The label will indicate the weight limits for use.



Sound Producing Devices

The navigation rules require sound signals to be made under certain circumstances. Meeting, crossing and overtaking situations, which will be described in some detail shortly, are examples of when sound signals are required. Recreational vessels are also required to sound signals during periods of reduced visibility. Your MasterCraft boat is equipped with a horn, but you may also purchase aftermarket devices in case of potential electrical disconnect or failure.

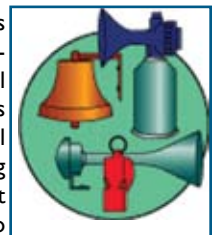

Note: The requirement to carry a bell on board no longer applies to vessels operating on International Waters.

Visual Distress Signals

All vessels used on coastal waters, the Great Lakes, territorial seas and those waters connected directly to them up to a point where a body of water is less than two miles wide, must be equipped with U.S.C.G.-approved visual distress signals. Vessels owned in the United States but operating on the high seas must be equipped with U.S.C.G.-approved visual distress signals.





Pyrotechnic visual distress signals must be Coast Guard-approved, in serviceable condition and readily accessible. This means that:

- They are marked with an expiration date. Expired signals may be carried as extra equipment, but cannot be counted toward meeting the visual distress signal requirement, since they may be unreliable.
- If pyrotechnic devices are selected, a minimum of three are required. That is, three signals for day use and three signals for night. Some pyrotechnic signals meet both day and night use requirements.
- Pyrotechnic devices should be stored in a cool, dry location, if possible. A watertight container painted red or orange and prominently marked "Distress Signals" or "Flares" is recommended.

U.S.C.G.-approved pyrotechnic visual distress signals and associated devices include pyrotechnic red flairs, hand-held or aerial; pyrotechnic orange smoke, hand-held or floating, or launchers for aerial red meteors or parachute flares.

Non-pyrotechnic devices may be allowed. These include an orange distress flag (day signal only) or an electric distress light (which is acceptable for night use). Use of these devices must still meet Coast Guard requirements, information for which is available online and from the Coast Guard.

Under Inland Navigation Rules, a high intensity white light flashing at regular intervals from 50-70 times per minute is considered a distress signal. Such devices do NOT count toward meeting the visual distress signal requirement, however. Regulations prohibit display of visual distress signals on the water under any circumstances except when assistance is required to prevent immediate or potential danger to persons on board a vessel.

All distress signals have distinct advantages. No single device is ideal under all conditions or suitable for all purposes. Pyrotechnics are universally recognized as excellent distress signals. However, there is potential for injury and property damage if not properly handled. These devices produce a very hot flame and the residue can cause burns and ignite flammable materials.

Pistol launched and hand-held parachute flares and meteors have many characteristics of a firearm and must be handled with caution. In some states they are considered a firearm and prohibited from use.

Check with local authorities regarding the best visual distress signal for use in the area in which you will be boating.

Registration, Numbering and Documentation

Although it might not be immediately obvious as to how this relates to boating safety, in fact it can be critical in emergencies. All undocumented vessels equipped with propulsion machinery must be registered in the state of principal use. A certificate of number will be issued upon registering the vehicle. These numbers must be displayed on your vessel. The owner/operator of the vessel must carry a valid certificate of number whenever the vessel

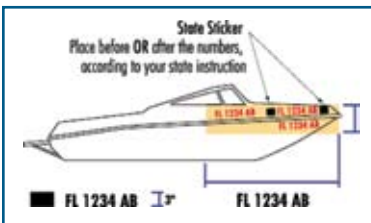

is in use. When moving to a new state of principal use, the certificate is valid for 60 days. Check with your state boating authority for registration requirements.

Numbers must be painted or permanently attached to each side of the forward half of the vessel. The validation stickers must be affixed within six inches of the registration number. With the exception of the vessel fee decal, no other letters or numbers may be displayed nearby. Lettering must be in plain, vertical block characters of not less than three (3) inches in height. Spaces or hyphens between letter and number groupings must be equal to the width of a letter other than "i" or a number other than "1."

The owner of a vessel must notify the agency which issued the certificate of number within fifteen (15) days if the vessel is transferred, destroyed, abandoned, lost, stolen or recovered, or if the certificate of number is lost, destroyed or the owner's address changed. If the certificate of number becomes invalid for any reason, it must be surrendered in the manner prescribed to the issuing authority within 15 days.

Operator's License

Some states are implementing operator's license requirements. These requirements vary widely. Whether operating a boat locally or in a remote location, operators should verify with state and local authorities regarding whether a license or training is required. This should be checked at least annually.

Recommended Equipment

The responsible boat owner will avoid potential problems on an outing by having additional equipment on board. Normally, the decision regarding the appropriate equipment to take on individual outings is dependent upon the body of water and the length of the trip. We suggest the following equipment as a minimum (your MasterCraft dealer can also assist you with additional recommendations):

- An anchor with at least 75 feet of line (in saltwater operation, particularly);
- A manual bailing device for removing water;
- A combination oar/boat hook;
- A day-and-night visual distress signal;
- A first aid kit and manual;
- An airway breathing tube;
- A waterproof flashlight;
- A non-electric horn or whistle;
- A set of local navigational charts;
- Mooring lines and fenders;
- Extra engine oil;
- A tool kit; and
- A portable, battery-operated AM/FM radio or weather radio/scanner.

Safety Afloat

The cause of many boating accidents is often the operator's failure to follow basic safety rules or written precautions. Many accidents can be avoided if the operator is completely familiar with the boat, its operation and can recognize potentially hazardous situations before an accident occurs.



Failure to comply with safety-related information and instructions may result in serious injury or death to you and/or others. Always use common sense when operating the boat or participating in any activities associated with the boat, including, but not limited to, periods of time when the boat engine is shut down and the boat is not in operation.

- Improper operation of the boat is extremely dangerous! Operators must read and understand all operating manuals supplied with the boat, before operation.
- On-board equipment must always conform to the governing federal, state and local regulations.
- Always attach the engine emergency safety shut-off lanyard to a part of your clothing (such as a belt loop) when operating the boat.



Never override or modify the engine emergency safety shut-off switch in any way.

- Never operate the boat while under the influence of alcohol or drugs.
- Never stand or allow passengers to stand in the boat or sit on the motor box or tower (where equipped) while underway. You or others may be thrown within or from the boat, which could result in serious injury or death.
- Prior to starting the engine, you must open the engine box and check the engine compartment and bilge for gasoline and oil vapors. You must also operate the blower for at least four (4) minutes. Failure to do so may result in fire and/or an explosion.



Failure to comply with the requirement of operating the blower for at least four (4) minutes before starting the engine may result in serious injury or death to you and/or others.

- **Never remove or modify any components of the fuel system. Removal or modification of any component of the fuel system may cause a hazardous situation and will void the warranty. The modern MasterCraft fuel delivery lines are pressurized and attempting to loosen or remove them may result in the uncontrolled release of fuel, which can be environmentally hazardous, and may potentially cause injury.**
- Never allow any type of spark or open flame on board. It may result in fire or explosion.



Skiing and Wakeboarding Safety

Skiers and wakeboarders are obligated to be as aware of the fundamental safety rules as operators. If you are new to water sports, you should seek certified training before starting. You may find it especially helpful to join a local water-sports club, if available, and the U.S.W.S.A. (United States Water Skiing Association).

- Always remember that the majority of water-skiing and wakeboarding injuries are the result of impacts with other objects, so always look where you are going and be aware of what is going on around you.
- Never put your arm, head or any other part of your body through the handle/bridle of the ski or wakeboarding line, nor wrap the line around any part of the body at any time.
- Never ski or wakeboard at night.
- Never ski or wakeboard directly in front of other boats.
- **When adding accessories to the tower, ensure that the total aggregate weight of the accessories does not exceed 85 lbs. (U.S.). Exceeding the limit may result in structural failure of the tower. MasterCraft strongly encourages the use of MasterCraft towers and accessories only as they have been tested and determined to meet product requirements, including weight.**



Towers should never have a total aggregate weight of accessories exceeding 85 lbs. (U.S.) total. Excessive weight can cause tower failure and the collapse of a tower or the disconnection of the tower from the deck, which could result in serious bodily injury or damage to the boat that is not covered by warranty.

- Never attempt to fold a tower without assistance. Folding a tower requires at least two (2) people.
- Never jump from a boat that is moving at any speed, nor enter or exit the water when the engine is running (ON). (See the *Common Sense Approach* section of this Owner's Manual for additional information regarding carbon monoxide peril.)
- Never climb, sit or stand on a tower. The tower is intended for towing only as noted.
- Make sure that everyone knows and uses approved skiing/wakeboarding hand signals and adheres to common skiing, wakeboarding and boating courtesy.
- Never ride on the ski platform or hold on to the ski platform while in the water during engine operation, including at idle. Carbon monoxide fumes are expelled from the lower transom areas of your boat and can cause death or serious illness.
- The above mandates are not all-inclusive. It is the boater's responsibility to operate the boat in a safe fashion and become familiar with any and all rules and regulations governing boat operation.



Do not tow more than two (2) persons at one time on a tow tower. The tow tower approved for use on your boat should be used only for water skis, wakeboards or recreational towables, and not for parasailing, kite flying or towing other boats. Do not add any attachments that are not approved for use on your MasterCraft boat. Do not climb on, sit on, stand on, jump off of or dive off of the tower. Never allow passengers to sit behind the tow rope attachment point. Never allow loose tow rope ends to dangle. Always be certain that all bolts are in place

and tight before and during use. When the tower is up, watch for low obstacles such as tree limbs, bridges or power lines.

Warning Plates and Labels

Read and note ALL warning plates and labels from bow to stern, including those that are installed inside the engine compartment, lockers and under seating. **YOU MUST READ AND ADHERE TO ALL CAUTIONS AND WARNINGS IN AND ON YOUR BOAT!**

Operator's Responsibilities

- Ensure the boat is in top operating condition and there are no hazards that impede your moving about the boat.
- Ensure the bilge is clean prior to starting.
- File a float plan, as described below, with a relative or friend.
- Have a complete knowledge of the operation and handling characteristics of your boat.
- Ensure that the boat is not loaded above the maximum capacity and that the load is properly distributed.
- Have familiarity with your starting location and your goal, and the waterways between.
- Maintain a safe speed at all times to avoid collisions.
- Keep an eye out for changing weather conditions and respond accordingly.
- Know and practice the navigational rules. Know and obey all federal and state regulations and operate the boat properly around all waterway markers.
- Maintain a clear, unobstructed view at all times, especially forward. Scan the water and avoid tunnel vision. Many boating collisions are caused by inattention.

Float Plan

A "float plan" is a written record indicating the planned destination and approximate length of time for the outing. Sample forms are available at the Coast Guard's website. One should be completed and left with a relative or friend prior to each trip. In case of an emergency or failure to return within a reasonable period of time, pertinent information will be available to assist local marine police or the Coast Guard in determining whether a search should be performed. Be sure to notify the float plan holder upon return.

Nautical Charts

Nautical charts are especially important to boaters planning trips, particularly on open waters. These charts show the nature and shape of the coast, depths of water, general configuration and character of the bottom. Other markings on the nautical charts include prominent landmarks, port facilities, aids to navigation, and marine hazards. Changes brought about by people and nature require that nautical charts be constantly maintained and updated to aid safe navigation.

National Ocean Service (NOS) charts may be purchased either directly by mail from the NOS Distribution Branch or through an authorized agent. There are more than 1,700 nautical chart agents who sell them.

FAA/National Aeronautical Charting Office
Distribution Division, AVN-530
6303 Ivy Lane, Suite 400
Greenbelt, MD 20770
Telephone: (301) 436-8301
Email: 9-AMC-chartsales@faa.gov
Website: <http://naco.faa.gov/>



Weather

Never leave the dock without first checking the local weather forecast. Weather information is available from television, radio, local newspaper, on-line or from a weather channel on a VHF radio.

At certain times of the year, weather can change rapidly and boaters should always keep an eye out for weather conditions. While boating, pay attention to the following:

- Weather changes generally come from the west.
 - Watch for cloud build-up, especially rapid, vertically rising clouds.
 - Sudden drop in temperature.
 - Sudden change in wind direction and/or speed.
 - On-board barometers should be checked every two-to-three hours. A rising barometer indicates fair weather and a rise in wind velocity; a falling barometer indicates stormy or rainy weather.
- What to do in severe weather:
- Reduce speed, keeping enough power to maintain headway.
 - Put on PFDs.
 - Turn on running lights.
 - Head for the nearest shore that is safe to approach, if possible.
 - Head bow of boat into waves at about a 45-degree angle.
 - Keep bilges free of water.
 - Seat passengers on bottom of the boat, near the centerline.
 - If the engine fails, tie a sea anchor on a line from the boat to keep the boat headed into the waves. A bucket will work as a sea anchor in an emergency.
 - Anchor the boat, if necessary.

Staying Afloat

It is commonly believed that someone dressed in heavy clothing or waders will experience considerably more difficulty staying afloat if they fall overboard. This is not true. Air trapped in clothing provides flotation and bending the knees will trap air in waders. To stay afloat:

- Remain calm. Do not thrash about or try to remove clothing or footwear. This leads to exhaustion and increases the loss of air that may keep you afloat.
- Keep your PFD on.
- Keep your knees bent.
- Float on your back and paddle slowly to safety.

Cold Water Survival

Sudden immersion in cold water can induce rapid, uncontrolled breathing, cardiac arrest and other physical body conditions, which can lead to drowning. Always wearing a PFD will help survival in rapid immersion situations.

In other situations when entry into cold water is necessary:

- Wear a PFD.
- Button all clothing.
- Cover your head if possible and enter the water slowly.
- Keep your head out of the water if at all possible.
- Assume the Heat Escape Lessening Posture (HELP) position as taught within a Coast Guard-taught safety course.

Hypothermia

Immersion in water speeds the loss of body heat and can lead to hypothermia. This is the abnormal lowering of internal body temperature. If a boat capsizes it will likely float on or just below the surface.

To reduce the effects of hypothermia, get in or on the boat. Try to get as much of your body out of the water as possible. If you can't get in the boat, a PFD will enable you to keep your head out of the water. This is very important because about 50 percent of body heat loss is from the head.

It may be possible to revive a drowning victim who has been under water for some time and shows no sign of life. Cases document instances where victims have been resuscitated after extended periods. Start CPR immediately and get the victim to a hospital as quickly as possible.

Immersion Suits

Immersion suits will delay the effects of hypothermia in cold water and are available through many retailers who specialize in sales of marine products. The suits should be stored and maintained according to the manufacturer's instructions.

Inflatable Life Rafts

An inflatable life raft can provide a survival platform for an extended period of time. Be sure the life raft is large enough for everyone on board when the boat operates off-shore. It should have the appropriate emergency equipment pack and should be professionally serviced periodically, according to the manufacturer's instructions. Coast Guard-approved life rafts must meet a number of stringent material and performance standards.

Anchoring

Anchoring is done for two principal reasons: first, to stop for fishing, swimming, lunch or an overnight stay, and secondly, to keep a boat from running aground in bad weather or as a result of engine failure.

When preparing to anchor, bring the bow of the vessel into the wind or current. Place the engine in neutral. When the boat comes to a stop, slowly lower the anchor. Do not throw the anchor over as it will tend to foul the anchor or tangle line. When the anchor line has been let out, back down on the anchor with the engine in idle reverse to help set the anchor. After it is firmly set, use reference points (landmarks) in relation to the boat to be sure that the boat is not drifting. Check the points frequently.

Communications

The following applies to salt water boating:

When boating off-shore, carry communications gear such as a marine VHF-FM and/or HF transceiver(s), appropriate to the operating area. Cellular phone coverage is available in many coastal areas. However, cellular phones should NOT be considered a substitute for VHF-FM marine band radios for emergency purposes.

Satellite EPIRBs (406 MHz) are designed to quickly and reliably alert rescue forces, indicate an accurate distress position, and guide rescue units to the distress scene, even when all other communica-



tions fail.

When activated, the satellite EPIRB transmits a distress signal with a beacon-unique identifying code. The system detects the signal, calculates an accurate distress position, checks the unique identifying code against the EPIRB registration database (vessel and point of contact information supplied by the owner) and routes the distress alert with registration information to the responsible U.S. Coast Guard (or International) Rescue Coordination Center (RCC). 406MHz EPIRBs with GPS (internal or attached) also provide an immediate GPS position in the information passed to the RCC.

Geostationary satellites make detection almost immediate. If the EPIRB does not have the ability to provide a GPS position, the process to determine a position takes about an hour on average and almost always less than two hours. Satellite EPIRBs also include a homing beacon and strobe to help rescue forces quickly locate the distress scene.

Satellite beacons have significant coverage, alerting timeliness, position accuracy, and signaling advantages over other types of EPIRBs (121.5 MHz). Before purchasing or using something other than the 406 MHz EPIRB, be sure to understand the capabilities and limitations.

In distress situations, press the transmit button and clearly say: MAYDAY, MAYDAY, MAYDAY. Follow this with the vessel name and/or description, the location, nature of emergency and number of people on-board. Then release the transmit button and wait for 10 seconds. If there is no response, repeat the MAYDAY call.

Further information and a complete listing of VHF channels and frequencies is available at: www.navcen.uscg.gov.

Law Enforcement

A vessel underway, when hailed by a Coast Guard vessel is required to heave to, or maneuver in such a manner that permits a boarding officer to come aboard.

Other federal, state and local law enforcement officials may board and examine a vessel. The Coast Guard may impose a civil penalty up to \$1,000 for failure to comply with equipment requirements; report a boating accident; or comply with other federal regulations. Failure to comply with the Inland Navigation Rules Act of 1980 can result in a civil penalty up to \$5,000. Details of the Act are available online or through the U.S. Coast Guard and the Coast Guard Auxiliary.

Improper use of a radio-telephone is a criminal offense. The use of obscene, indecent or profane language during radio communications is punishable by a \$10,000 fine, imprisonment for two years or both. Other penalties exist for misuse of a radio, such as improper use of Channel 16 VHF-FM. Channel 16 is a calling and distress channel. It is not to be used for conversation or radio checks. Such communications should be conducted on an authorized channel.

Note that there are stringent requirements regarding pollution,



discharge of oil, discharge of garbage and the operation and discharge from sanitation devices. It is the boat owner's and operator's responsibility to determine what the laws and regulations are and to ensure that those laws and regulations are respected and enforced.
Details are available through the Coast Guard.

COMMON SENSE APPROACH

This Owner's Manual has been developed to help ensure an enjoyable experience as you boat, wakeboard and ski with a fabulous MasterCraft boat. As stated earlier, this information is not all-inclusive. There are many factors to consider and additional information that you need to research before undertaking any boating activity.

In addition to reading this Owner's Manual or other related material, and familiarizing yourself with the proper operation of the MasterCraft boat, you should also always use common sense when boating. For example, when anchoring the boat, you **MUST** turn OFF the engine. In most models, exhaust fumes containing carbon monoxide are emitted from the exhaust flap area of the transom immediately below the swim platform. **No one should ever be on the swim platform or transom while the engine is operating. This includes while using the shower option in those models where the engine must run in order to create hot water. In those instances, showering must never be done on the swim platform or transom as the carbon monoxide fumes are toxic.**



Carbon monoxide is a colorless, tasteless, odorless and poisonous gas that accumulates rapidly and can cause serious injury or death. Exposure to carbon monoxide can be fatal in a matter of minutes. Exposure to even low concentrations of carbon monoxide must not be ignored because the effects of exposure to carbon monoxide can build up and be just as lethal as high concentrations. Carbon monoxide from exhaust pipes of inboard or outboard engines may build up inside and outside the boat in areas near exhaust vents, particularly during slow-speed operations. STAY AWAY from these exhaust vent areas, which are located at the stern of the boat, and DO NOT swim or engage in any watersports or other activities in or near the stern area of the boat, including, without limitation, the swim platform and the rear sun deck, when the engine is in operation. Under no circumstances should the owner and/or operator allow persons to hold onto the swim platform while the engine is operating and the boat is in motion. These activities (sometimes known as "teak surfing" or "platform dragging," where the participant holds onto the swim platform and is pulled through the water, and/or "body surfs" immediately behind the boat) are extremely dangerous, highly likely to result in death or serious bodily injury, and are a misuse of this product.



All boats have weight limits. Failure to adhere to the posted limits can cause operation instability and/or the boat to sink. This may result in serious injury or death, as well as significant damage to the boat, which will not be covered by warranty.

Overloading a boat may cause it to become unstable and may potentially result in the boat's flotation system becoming overwhelmed. Too much weight can sink any boat! Within this Manual and on a label mounted in each boat, except in the 280 and 265 models, is the weight limit for that specific model. Bear in mind that total weight limits include water ballast, gear brought onto the boat, additional options and all

people. Equally critical is how weight is distributed throughout the boat. If too much weight is placed in one area it can have serious impact on maintaining control. Items and people can also shift positions during operation, potentially causing a dangerous situation.

Model 280 and 265 are Yacht Certified and do not display a listed weight limit on the boat. See information specific to those models for guidance.

In calculating the amount of weight, you must also take into consideration the weight of the gasoline and any ballast added. The weight of gasoline is approximately 5.8 to 6.5 pounds (U.S.) per gallon, depending upon the weather and other factors, including the addition of ethanol, which is slightly denser and will add very slightly to the overall weight. Water pumped into the ballast system will add 8.3 pounds (U.S.) for every gallon added.

Care should also be taken to avoid interfering with the boat operator's line of sight when the boat is underway. This applies particularly to individuals riding in the bow. It is possible to quite unintentionally obscure the driver's view. Even momentary interference can result in the driver's inability to respond to a situation that requires avoidance of another vessel or submerged or partially-submerged objects. Everyone on board should always pay attention to other vessels, people and objects located in close proximity to the boat, activities taking place in or near the water, and should always be supportive of the boat operator.



MasterCraft strongly encourages individuals to wear Personal Flotation Devices (PFDs). In many states, it is a legal requirement for children to wear them at all times while on board. Non-swimmers and swimmers of limited ability of any age should never be without a PFD while on a boat.

Avoid any activity that may result in damage to the boat, thereby voiding the warranty. Some things, such as avoiding stationary objects, are obvious. However, even less obvious activities can cause damage to a boat, no matter how well-built. For example, while a beach or shoreline may seem soft while walking on it, running a boat up onto shore may result in significant scratches in the fiberglass finish. The causes of many kinds of damage are usually quite obvious to trained service personnel.

MasterCraft cannot anticipate every type of activity or neglect that could result in damage to the boat or that may cause illness, injury or even death to boaters. The operator, owner and/or all persons on board are responsible for using common sense and a careful thought process to ensure that every measure has been taken to keep boating enjoyable for many years to come. A MasterCraft boat can be the source of countless hours of family fun, as well as building friendships. But the boating experience remains safe only if YOU use your head before, during and after your boating activity.

As you anticipate many good times ahead with the MasterCraft boat, be sure that, first and foremost, you are well-prepared to be responsible.

RULES OF THE OPEN WATER



Just as there are rules that apply when driving a vehicle on the street, there are waterway rules that apply when you are driving a boat on the water. These rules are used internationally, and they are enforced by the United States Coast Guard and local agencies. You should be aware of these rules and follow them whenever you encounter another vessel on the water.

In various geographic locations, certain rules prevail that may be unique to the locale. Each state also has laws and boating limitations that may be applicable only within their boundaries. It is the operator's responsibility to seek out this information and become familiar with all safety-related information, laws and rules governing boating operation.

The rules presented in this Owner's Manual are condensed and have been provided for convenience only. Consult your local U.S. Coast Guard Auxiliary (USCGA), Department of Motor Vehicles (DMV) or Department of Natural Resources (DNR) for a complete set of rules governing the waters in which you will be using your boat. If you plan to travel—even for a short trip—you would be well-served to contact the regional USCGA, DMV or DNR in the area where you will be boating. Often, basic information is available through websites sponsored and prepared by these organizations and governing bodies.

The General Prudential Rule

This rule is called **Rule 2 in the International Rules** and says, **"In obeying and construing these rules due regard shall be had to all dangers of navigation and collision, and to any special circumstances, which may render a departure from the above rules necessary in order to avoid immediate danger."**

Steering and Sailing Rules/Sound Signals

Any time two (2) vessels on the water meet one another, one vessel has the right-of-way. It is called the **stand-on vessel**. The vessel that does not have the right-of-way is called the **give-way** or **burdened vessel**.

These rules determine which vessel has the right of way, and accordingly, what each vessel should do.

The vessel with the right-of-way has the duty to continue its course and speed, except to avoid an immediate collision. When you maintain your direction and speed, the other vessel will be able to

determine how best to avoid you.

The vessel that does not have the right of way has the duty to take positive and timely action to stay out of the way of the stand-on vessel. Normally, the give-way vessel should not cross in front of the stand-on vessel. Slow down or change direction briefly and pass behind the other vessel. You should always move in such a way that the stand-on operator can see what you are doing.

Rules When Encountering Vessels

There are three (3) main situations in which you may encounter other vessels, and you must avoid a collision. These are:

- **Meeting** (you are approaching another vessel head-on).
- **Crossing** (you are traveling across the other vessel's path).
- **Overtaking** (you are passing or being passed by another vessel).

Meeting

If you are meeting another vessel head-on, and you are close enough to run the risk of collision, neither of you has the right-of-way. Both of you should alter course to avoid an accident. You should keep the other vessel on your port (left) side. (This rule doesn't apply if both of you can clear each other by continuing your set course and speed.)

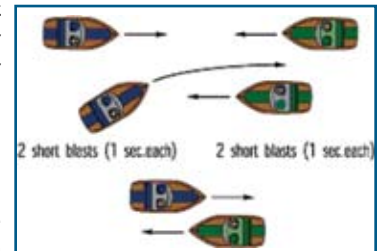
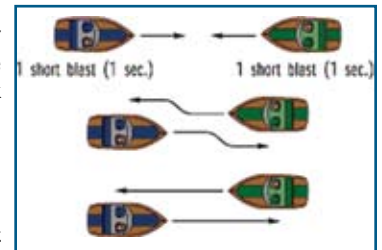

Crossing

When two (2) power-driven vessels are crossing each other's path close enough to run the risk of collision, the vessel that views the crossing vessel to the starboard (right) side must give way.

If the other vessel is to the port (left) side, you are the stand-on vessel, and provided

the other vessel gives you the right-of-way, maintain your course and direction.

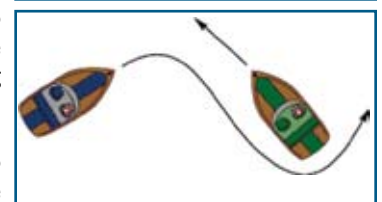

Overtaking

If you are passing another vessel, you are the give-way vessel. This means that the other vessel is expected to maintain its course and speed. You must stay out of its way as you clear it, altering course and speed as necessary.

Conversely, if you are being passed by another vessel, you are the stand-on vessel, and you should maintain your speed and direction so that the vessel can be steered around you.

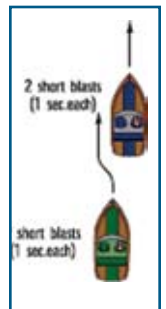

Other Special Situations

There are additional rules to remember when operating your boat around other vessels, such as:

- When navigating in narrow channels, you should keep to the right when it is safe and practical to do so.
- When preparing to go around a bend that may obstruct your view of other water vessels, you should sound a prolonged blast on the horn or with a whistle for four (4) to six (6) seconds. Even if no reply is heard, you should still proceed around the bend with caution.

Sailing Vessel Right-of-Way

Sailing vessels should normally be given the right-of-way. The exceptions to this are:

- When the sailing vessel is overtaking the power-driven vessel, the power-driven vessel has the right-of-way.
- Sailing vessels should keep clear of any fishing vessel.
- In a narrow channel, a sailing vessel should not hamper the safe passage of a power-driven vessel that can navigate only in such a channel.

Fishing Vessel Right-of-Way

Under international rules, all vessels that are fishing with nets, lines or trawls are considered to be fishing vessels; however, boats with trolling lines are not considered fishing vessels.

Fishing vessels have the right of way, regardless of position, but these vessels cannot impede the passage of other vessels in narrow channels.



Reading Buoys and Other Markings

The waters of the United States are marked for safe navigation by the lateral system of buoyage. The markers and buoys you encounter will have an arrangement of shapes, colors, numbers and lights to show which side of the buoy a boater should pass when navigating in a particular direction.

The markings on these buoys are oriented from the perspective of being entered from a seaward direction while the boater is going toward the port. Red buoys are passed on the starboard (right) side when proceeding from open water into port, and green buoys are passed on the port (left) side. When navigating out of port, your position to the buoys should be reversed: red buoys to port (left) and green buoys to starboard (right).

Many bodies of water are entirely within the boundaries of a single state. The Uniform State Waterway Marking Systems have been devised for these waters. This system uses buoys and signs with distinctive shapes and colors to show regulatory or advisory information. These markers are white with black letters and orange borders. The information signifies speed zones, restricted areas, danger areas and general information.

Remember: Markings may vary by geographic location. Always consult appropriate boating authorities before boating in unfamiliar waters.

GUIDE TO INDIVIDUAL MODELS

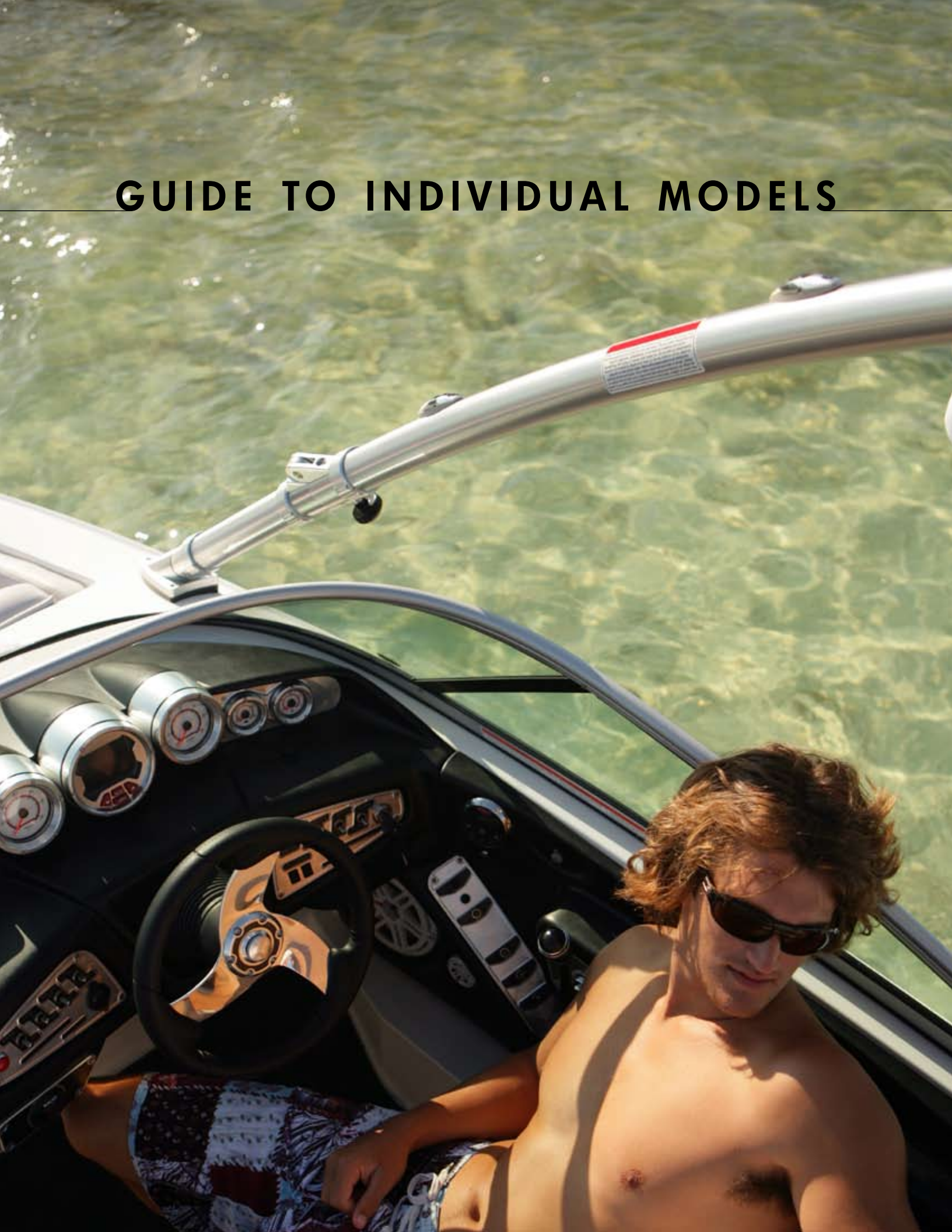

PROSTAR 190

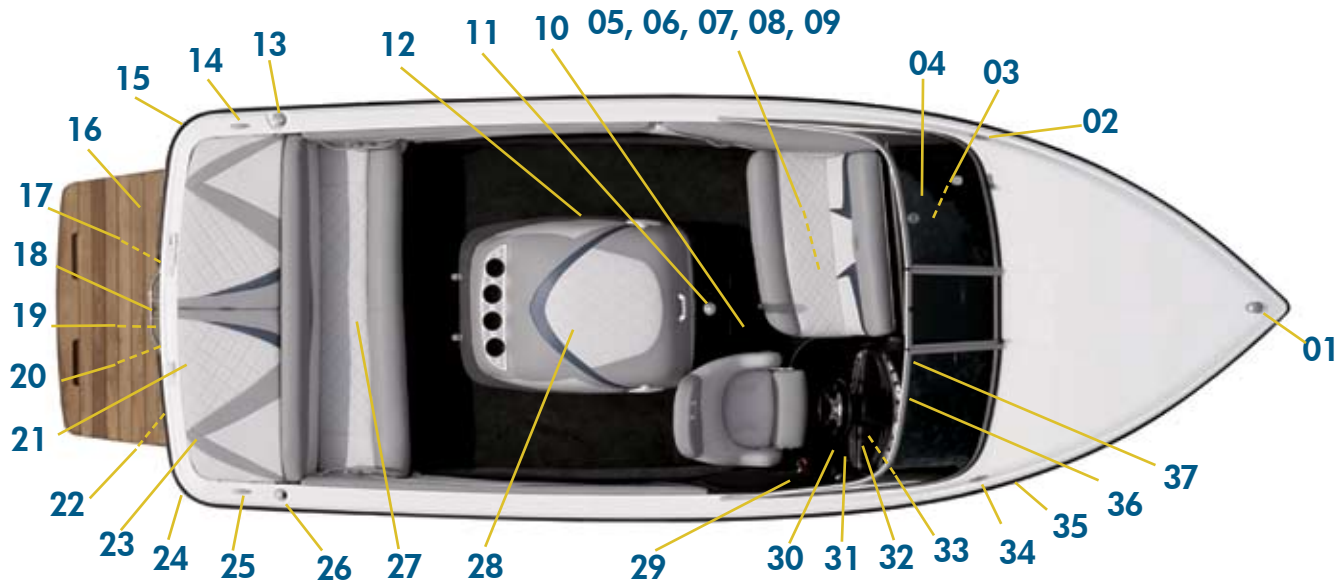

- | | | | |
|----|--|----|--|
| 01 | Bow light | 31 | Instrument panel (details elsewhere in this section) |
| 02 | Bow cleat | 32 | Subwoofer (where equipped) |
| 03 | Stereo CD Player (inside glove box, where equipped) Sirius
Satellite Radio (where equipped) | 33 | Circuit breaker panel (on kick panel beneath instrument panel) |
| 04 | Glove box | 34 | Bow cleat |
| 05 | Battery (located in void beneath observer seat) | 35 | Bilge thru-hull outlet |
| 06 | MTS Ballast System fill (where equipped, beneath observer seat) | 36 | Adjustable mirror |
| 07 | Hand-held fire extinguishers (beneath observer seat) | 37 | Built-in cooler |
| 08 | Amp (where equipped, beneath observer seat) | | |
| 09 | iPod interface (where equipped) | | |
| 10 | Center drain plug | | |
| 11 | Ski pylon | | |
| 12 | Fire port | | |
| 13 | Fuel tank filler | | |
| 14 | Stern cleat | | |
| 15 | Ballast vent | | |
| 16 | Swim platform | | |
| 17 | Engine exhaust (two below swim platform) | | |
| 18 | Transom rail with tow eye (where equipped) | | |
| 19 | Transom drain plug (center beneath swim platform) | | |
| 20 | Under-platform ladder (where equipped) | | |
| 21 | Transom stereo remote (where equipped) | | |
| 22 | Underwater lights (two where equipped under swim platform) | | |
| 23 | Shower wand & switch/Slick Boot wand & switch (where
equipped, inside storage compartment) | | |
| 24 | Ballast thru-hull vent | | |
| 25 | Stern cleat | | |
| 26 | Stern light receptacle (if equipped with tower, the light will be in
center aft of tower) | | |
| 27 | Rear Ballast System fill (where equipped) | | |
| 28 | Engine compartment | | |
| 29 | Shift/throttle control | | |
| 30 | Steering wheel | | |

Boats may also be equipped with towers, which may include stereo speakers, lights and/or tower-mounted mirror

Storage space is located:

- Under observer's seat (including into bow)
- Under aft seating
- Under aft sun pad

PROSTAR 197, X-7

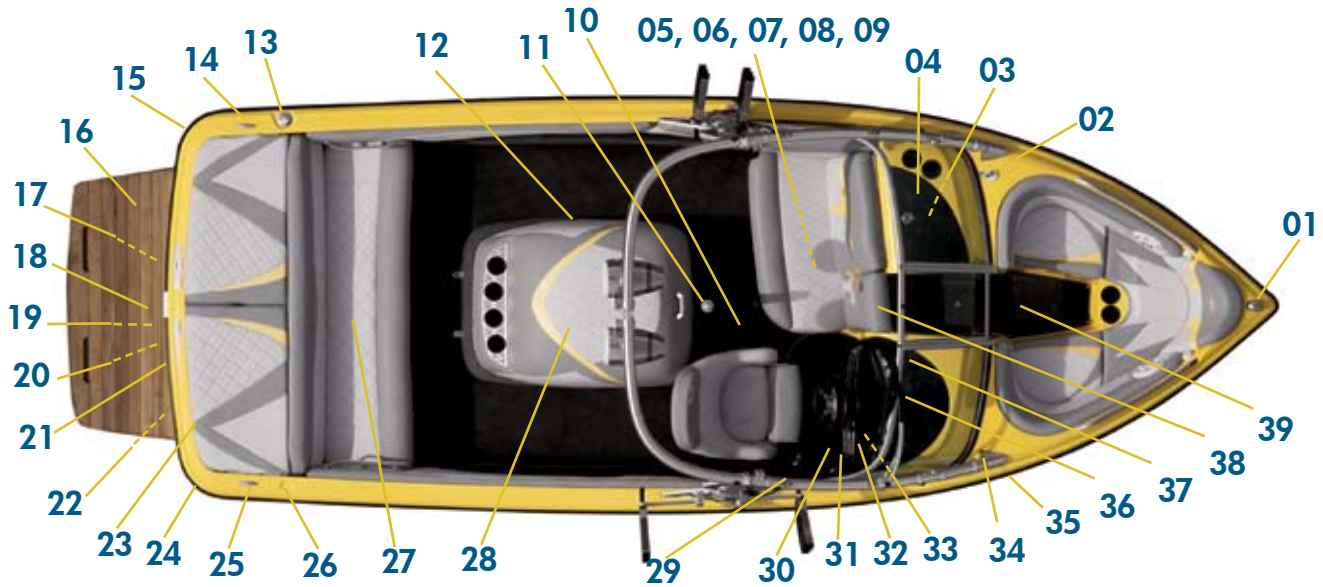

- | | | | |
|----|---|----|--|
| 01 | Bow light | 31 | Instrument panel (details elsewhere in this section) |
| 02 | Bow cleat | 32 | Subwoofer (where equipped) |
| 03 | Stereo CD Player (inside glove box, where equipped) Sirius Satellite Radio (where equipped) | 33 | Circuit breaker panel (on kick panel beneath instrument panel) |
| 04 | Glove box | 34 | Bow cleat |
| 05 | Battery (located in void beneath observer seat) | 35 | Bilge thru-hull outlet |
| 06 | MTS Ballast System fill (where equipped, beneath observer seat) | 36 | Adjustable mirror |
| 07 | Hand-held fire extinguishers (beneath observer seat) | 37 | Built-in cooler |
| 08 | Amp (where equipped, beneath observer seat) | 38 | Folding walk-thru seat |
| 09 | iPod interface (where equipped) | 39 | Bow filler cushion (where equipped) |
| 10 | Center drain plug | | |
| 11 | Ski pylon | | |
| 12 | Fire port | | |
| 13 | Fuel tank filler | | |
| 14 | Stern cleat | | |
| 15 | Ballast vent | | |
| 16 | Swim platform | | |
| 17 | Engine exhaust (two below swim platform) | | |
| 18 | Transom rail with tow eye (where equipped) | | |
| 19 | Transom drain plug (center beneath swim platform) | | |
| 20 | Under-platform ladder (where equipped) | | |
| 21 | Transom stereo remote (where equipped) | | |
| 22 | Underwater lights (two where equipped under swim platform) | | |
| 23 | Shower wand & switch/Slick Boot wand & switch (where equipped, inside storage compartment) | | |
| 24 | Ballast thru-hull vent | | |
| 25 | Stern cleat | | |
| 26 | Stern light receptacle (if equipped with tower, the light will be in center aft of tower) | | |
| 27 | Rear Ballast System fill (where equipped) | | |
| 28 | Engine compartment | | |
| 29 | Shift/throttle control | | |
| 30 | Steering wheel | | |

Boats may also be equipped with towers (standard on X-7), which may include stereo speakers, lights and/or tower-mounted mirror

Storage space is located:

- Under observer's seat
- Under bow seating
- Under aft seating
- Under aft sun pad

PROSTAR 214, X-14

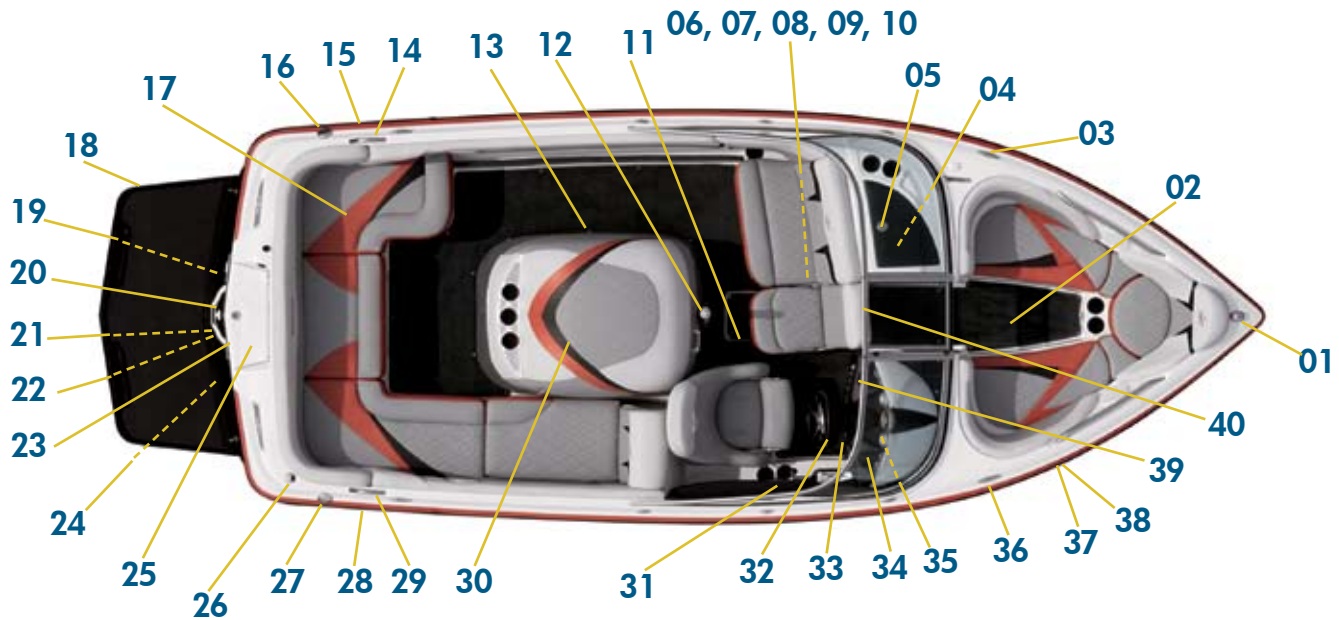

- | | | | |
|----|---|----|--|
| 01 | Bow light | 31 | Shift/throttle control |
| 02 | Bow filler cushion (where equipped) | 32 | Steering wheel |
| 03 | Bow cleat | 33 | Instrument panel (details elsewhere in this section) |
| 04 | Stereo CD Player (inside glove box, where equipped) Sirius Satellite Radio (where equipped) | 34 | Subwoofer (where equipped) |
| 05 | Glove box | 35 | Circuit breaker panel (on kick panel beneath instrument panel) |
| 06 | Battery (located in void beneath observer seat) | 36 | Bow cleat |
| 07 | MTS Ballast System fill (where equipped, beneath observer seat) | 37 | Ballast thru-hull vent |
| 08 | Hand-held fire extinguishers (beneath observer seat) | 38 | Bilge thru-hull outlet |
| 09 | Amp (where equipped, beneath observer seat) | 39 | Adjustable mirror |
| 10 | iPod interface (where equipped) | 40 | Folding walk-thru seat |
| 11 | Center drain plug | | |
| 12 | Ski pylon | | |
| 13 | Fire port | | |
| 14 | Fuel tank filler | | |
| 15 | Ballast thru-hull vent | | |
| 16 | Stern cleat | | |
| 17 | MTS Ballast System tank (where equipped) | | |
| 18 | Swim platform | | |
| 19 | Engine exhaust | | |
| 20 | Transom rail with tow eye | | |
| 21 | Transom drain plug (center beneath swim platform) | | |
| 22 | Under-platform ladder (where equipped) | | |
| 23 | Transom stereo remote (where equipped) | | |
| 24 | Underwater lights (two where equipped under swim platform) | | |
| 25 | Shower wand & switch/Slick Boot wand & switch (where equipped, inside storage compartment) | | |
| 26 | Stern light receptacle (if equipped with tower, the light will be in center aft of tower) | | |
| 27 | Fuel tank filler | | |
| 28 | Ballast thru-hull vent | | |
| 29 | Stern cleat | | |
| 30 | Engine compartment | | |

Boats may also be equipped with towers (standard on X-14), which may include stereo speakers, lights and/or tower-mounted mirror

Storage space is located:

- Under observer's seat
- Under bow seating
- Under aft seating
- Under aft sun pad

PROSTAR 214, X-14 V-DRIVE

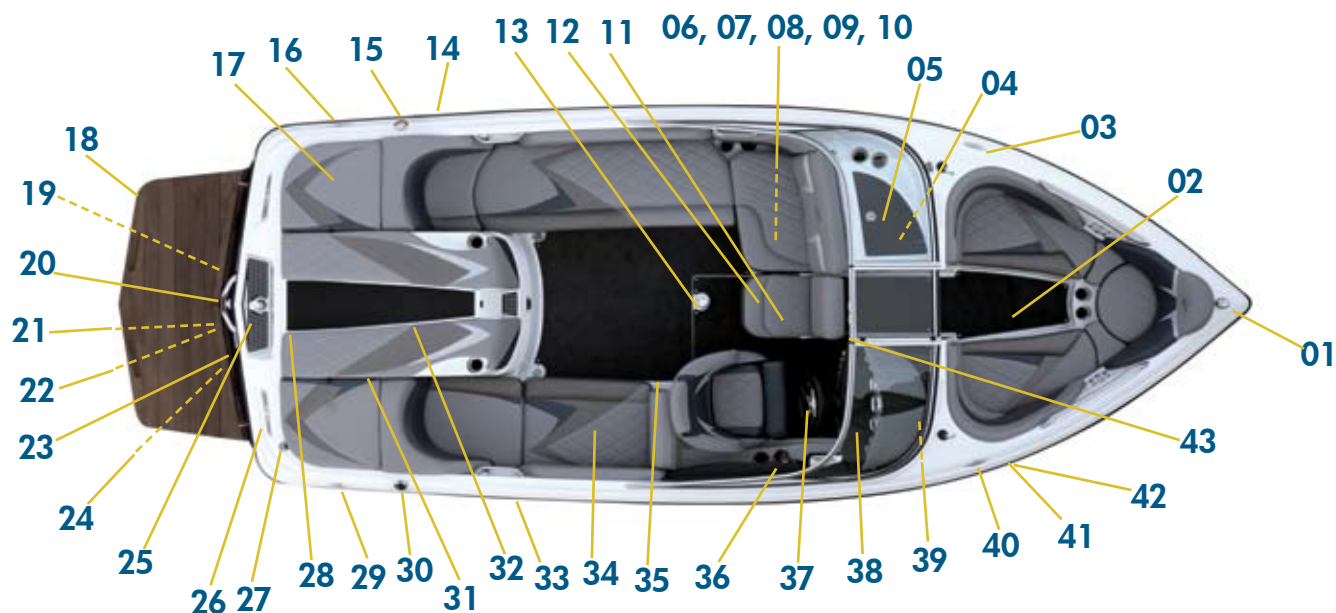

- | | | | |
|----|---|----|--|
| 01 | Bow light | 31 | Automatic fire extinguisher |
| 02 | Bow filler cushion (where equipped) | 32 | Engine compartment |
| 03 | Bow cleat | 33 | Ballast thru-hull pump-out |
| 04 | Stereo CD Player (inside glove box, where equipped) Sirius Satellite Radio (where equipped) | 34 | Cooler (located under seat) |
| 05 | Glove box | 35 | Subwoofer (where equipped) |
| 06 | Battery (located in void beneath observer seat) | 36 | Shift/throttle control |
| 07 | MTS Ballast System fill (where equipped, beneath observer seat) | 37 | Steering wheel |
| 08 | Hand-held fire extinguisher (beneath observer seat) | 38 | Instrument panel (details elsewhere in this section) |
| 09 | Amp (where equipped, beneath observer seat) | 39 | Circuit breaker panel (on kick panel beneath instrument panel) |
| 10 | iPod interface (where equipped) | 40 | Bow cleat |
| 11 | Center drain plug | 41 | Ballast thru-hull vent |
| 12 | Convertible jump seat (where equipped) or walk-thru seat (where equipped) | 42 | Bilge pump-out outlet |
| 13 | Ski pylon | 43 | Adjustable mirror |
| 14 | Ballast thru-hull vent | | |
| 15 | Fuel tank filler | | |
| 16 | Stern cleat | | |
| 17 | MTS Ballast system tank (where equipped) | | |
| 18 | Swim platform | | |
| 19 | Engine exhaust (under swim platform) | | |
| 20 | Transom rail with tow eye | | |
| 21 | Transom drain plug (center beneath swim platform) | | |
| 22 | Under-platform ladder (where equipped) | | |
| 23 | Transom stereo remote (where equipped) | | |
| 24 | Underwater lights (two where equipped under swim platform) | | |
| 25 | Aft ski pylon | | |
| 26 | Blower exhaust (top of deck near transom) | | |
| 27 | Stern light receptacle (if equipped with tower, the light will be in center aft of tower) | | |
| 28 | Shower wand & switch/Slick Boot wand & switch (where equipped, inside storage compartment) | | |
| 29 | Stern cleat | | |
| 30 | Fuel tank filler | | |

Boats may also be equipped with towers (standard on X-14V), which may include stereo speakers, lights and/or tower-mounted mirror

Storage space is located:

- Under observer's seat
- Under bow seating
- Under aft seating
- Under port side seat

(At press time, the final determination of the location of the fire suppression system manual override had not been finalized. Prior to operating the boat for the first time, the boat owner must determine this information from an authorized MasterCraft dealer.)

X-1

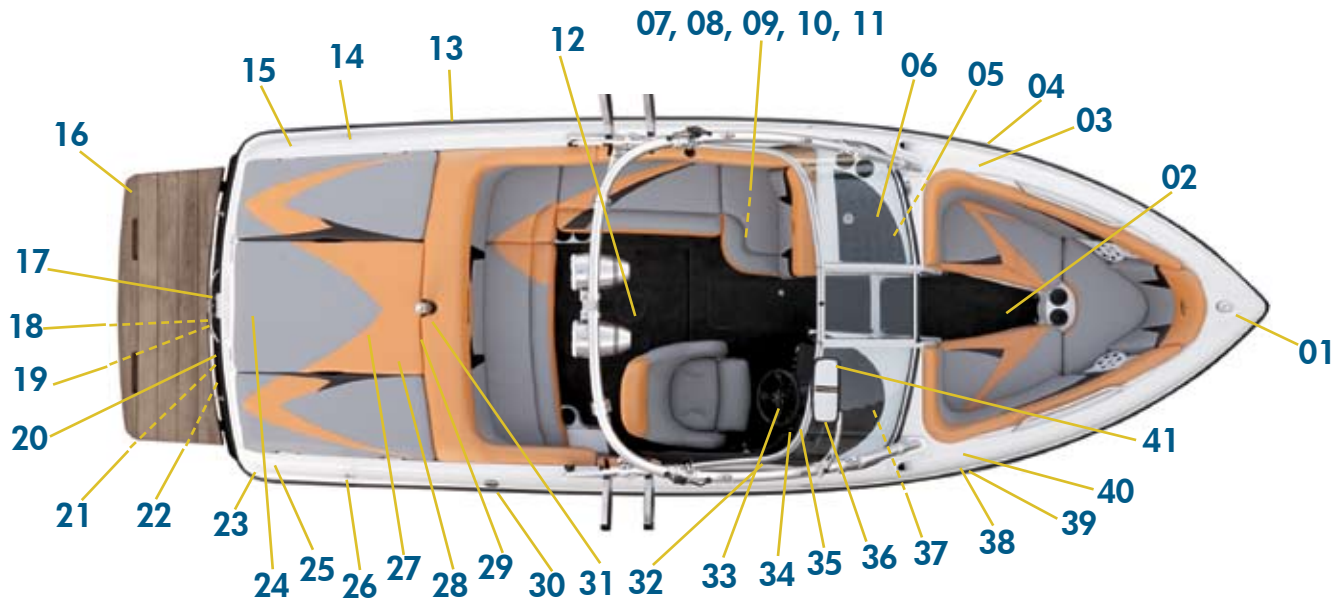

- | | | | |
|----|---|----|--|
| 01 | Bow light | 31 | Ski pylon |
| 02 | Bow filler cushion (where equipped) | 32 | Shift/throttle control |
| 03 | Bow cleat | 33 | Steering wheel |
| 04 | Ballast thru-hull pump-out | 34 | Fire suppression unit manual override |
| 05 | Stereo CD Player (inside glove box, where equipped) Sirius Satellite Radio (where equipped) | 35 | Instrument panel (details elsewhere in this section) |
| 06 | Glove box | 36 | Subwoofer (where equipped) |
| 07 | Battery (located in void beneath observer seat) | 37 | Circuit breaker panel (on kick panel beneath instrument panel) |
| 08 | Ballast System tank (where equipped, beneath observer seat) | 38 | Ballast thru-hull vent |
| 09 | Hand-held fire extinguisher (beneath observer seat) | 39 | Bilge thru-hull outlet |
| 10 | Amp (where equipped, beneath observer seat) | 40 | Bow cleat |
| 11 | iPod interface (where equipped) | 41 | Adjustable mirror |
| 12 | Center drain plug | | |
| 13 | Ballast thru-hull pump-out | | |
| 14 | Fuel tank filler | | |
| 15 | Stern cleat | | |
| 16 | Swim platform | | |
| 17 | Transom rail with tow eye | | |
| 18 | Transom drain plug (center beneath swim platform) | | |
| 19 | Under-platform ladder (where equipped) | | |
| 20 | Transom stereo remote (where equipped) | | |
| 21 | Underwater lights (two where equipped under swim platform) | | |
| 22 | Engine exhaust (two below swim platform) | | |
| 23 | Stern light receptacle (if equipped with tower, the light will be in center aft of tower) | | |
| 24 | Shower wand & switch/Slick Boot wand & switch (where equipped, inside storage compartment) | | |
| 25 | Stern cleat | | |
| 26 | Ballast thru-hull vent | | |
| 27 | Engine compartment | | |
| 28 | Automatic fire extinguisher | | |
| 29 | Ballast system | | |
| 30 | Fuel tank filler | | |

Boats are equipped with towers, which may include stereo speakers, lights and/or tower-mounted mirror

Storage space is located:

- Under observer's seat
- Under bow seating
- Under aft seating
- Under aft sun pad

MARISTAR 200, X-2

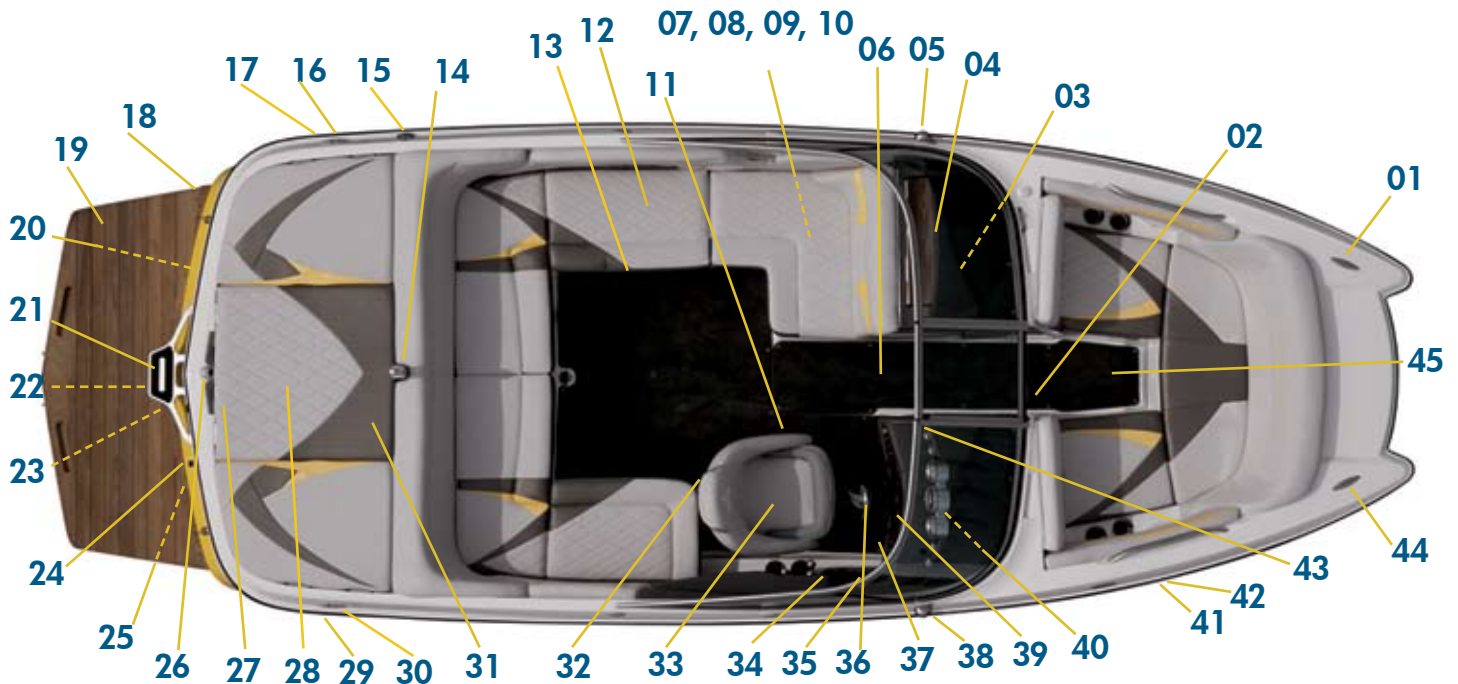

- | | | | |
|----|--|----|--|
| 01 | Bow cleat | 31 | Automatic fire extinguisher |
| 02 | Bow filler cushion (where equipped) | 32 | Subwoofer |
| 03 | Stereo CD Player (inside glove box, where equipped); Sirius Satellite Radio (where equipped) | 33 | Heated seat (where equipped) |
| 04 | Glove box | 34 | Armrest stereo remote |
| 05 | Nav/anchor light | 35 | Shift/throttle control |
| 06 | Walk-thru seat (where equipped) | 36 | Steering wheel |
| 07 | Batteries (including ON-OFF switch) | 37 | Fire suppression unit manual override |
| 08 | Amp (where equipped) | 38 | Nav/anchor light |
| 09 | Hand-held fire extinguisher (beneath observer seat) | 39 | Instrument panel (details elsewhere in this section) |
| 10 | Heated observer seat (where equipped) | 40 | Circuit breaker panel (on kick panel beneath instrument panel) |
| 11 | Center drain plug | 41 | Ballast thru-hull vent |
| 12 | Cooler (located under seat) | 42 | Bilge thru-hull outlet |
| 13 | Cockpit table mount (where equipped) | 43 | Adjustable mirror |
| 14 | Ski pylon | 44 | Bow cleat |
| 15 | Fuel tank filler | 45 | Ballast tank located beneath floorboard |
| 16 | Stern cleat | | |
| 17 | Ballast thru-hull vent | | |
| 18 | Wake adjustment plate (located under swim platform, where equipped) | | |
| 19 | Swim platform | | |
| 20 | Engine exhaust | | |
| 21 | Transom rail with tow eye | | |
| 22 | Transom drain plug (center beneath swim platform) | | |
| 23 | Under-platform ladder (where equipped) | | |
| 24 | Transom stereo remote (where equipped) | | |
| 25 | Underwater lights (two where equipped under swim platform) | | |
| 26 | Nav/anchor light (if equipped with tower, the light will be in center aft of tower) | | |
| 27 | Shower wand and switch/Slick Boot wand and switch (where equipped, inside compartment) | | |
| 28 | Engine compartment | | |
| 29 | Bilge thru-hull vent | | |
| 30 | Stern cleat | | |

Boats may also be equipped with towers (standard on X-2), which may include stereo speakers, lights and/or tower-mounted mirror

Storage space is located:

- Under observer's seat
- Under bow seating
- Under aft and wrap-around seating
- Under port and starboard sun pads

MARISTAR 215, X-15

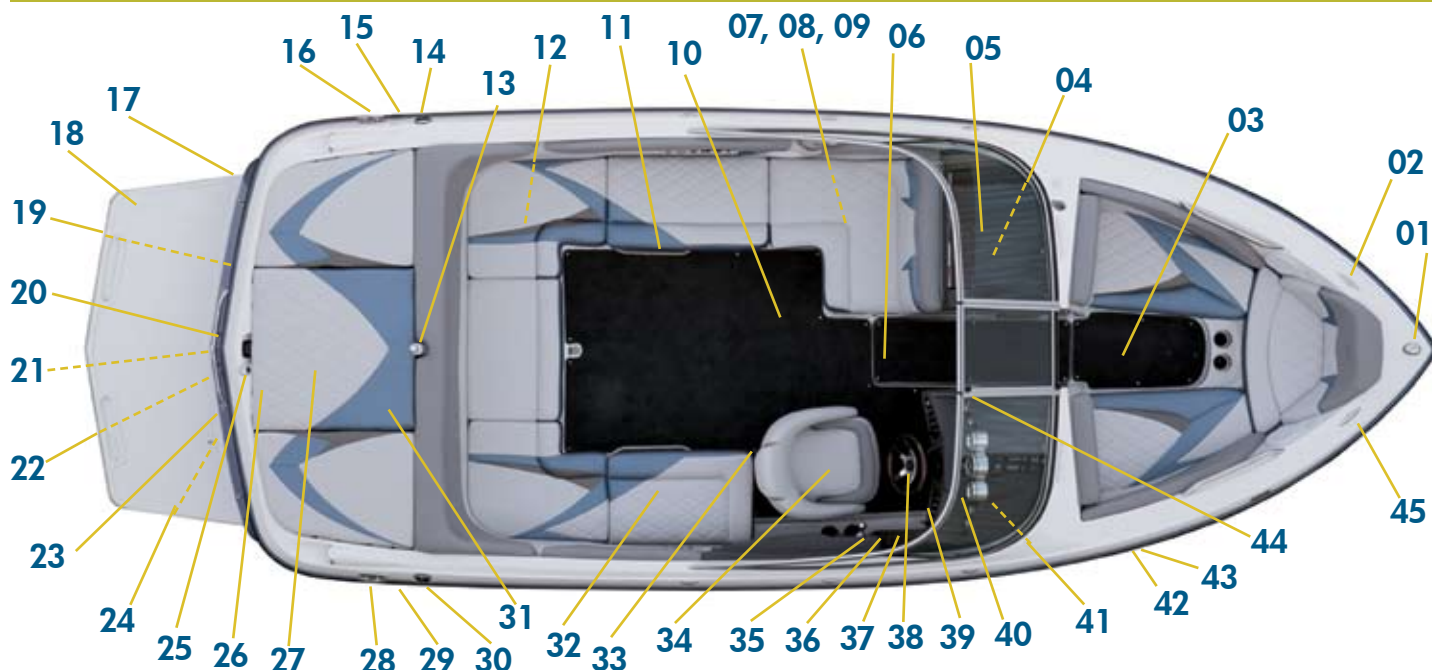

- | | | | |
|----|--|----|--|
| 01 | Bow light | 31 | Automatic fire extinguisher |
| 02 | Bow cleat | 32 | Cooler (under seat) |
| 03 | Bow filler cushion (where equipped) | 33 | Subwoofer |
| 04 | Stereo CD Player (inside glove box, where equipped); Sirius Satellite Radio (where equipped) | 34 | Heated seat (where equipped) |
| 05 | Glove box | 35 | Armrest stereo remote |
| 06 | Walk-thru seat (where equipped) | 36 | Shift/throttle control |
| 07 | Amp (where equipped) | 37 | iPod interface (where equipped) |
| 08 | Hand-held fire extinguisher (beneath observer seat) | 38 | Steering wheel |
| 09 | Heated observer seat (where equipped) | 39 | Fire suppression unit manual override |
| 10 | Center drain plug | 40 | Instrument panel (details elsewhere in this section) |
| 11 | Cockpit table mount (where equipped) | 41 | Circuit breaker panel (on kick panel beneath instrument panel) |
| 12 | Batteries (including ON-OFF switch) | 42 | Ballast thru-hull vent |
| 13 | Ski pylon | 43 | Bilge thru-hull outlet |
| 14 | Fuel tank filler | 44 | Adjustable mirror |
| 15 | Ballast thru-hull vent | 45 | Bow cleat |
| 16 | Stern cleat | | Ballast tank located beneath floorboard |
| 17 | Wake adjustment plate (located under swim platform, where equipped) | | |
| 18 | Swim platform | | |
| 19 | Engine exhaust | | |
| 20 | Transom rail with tow eye | | |
| 21 | Transom drain plug (center beneath swim platform) | | |
| 22 | Under-platform ladder (where equipped) | | |
| 23 | Transom stereo remote (where equipped) | | |
| 24 | Underwater lights (two where equipped under swim platform) | | |
| 25 | Stern light receptacle (if equipped with tower, the light will be in center aft of tower) | | |
| 26 | Shower wand and switch/Slick Boot wand and switch (where equipped, inside compartment) | | |
| 27 | Engine compartment | | |
| 28 | Stern cleat | | |
| 29 | Bilge thru-hull vent | | |
| 30 | Fuel tank filler | | |

Boats may also be equipped with towers (standard on X-15), which may include stereo speakers, lights and/or tower-mounted mirror

Storage space is located:

- Under observer's seat
- Under bow seating
- Under aft and wrap-around seating
- Under port and starboard sun pads

MARISTAR 230, X-30

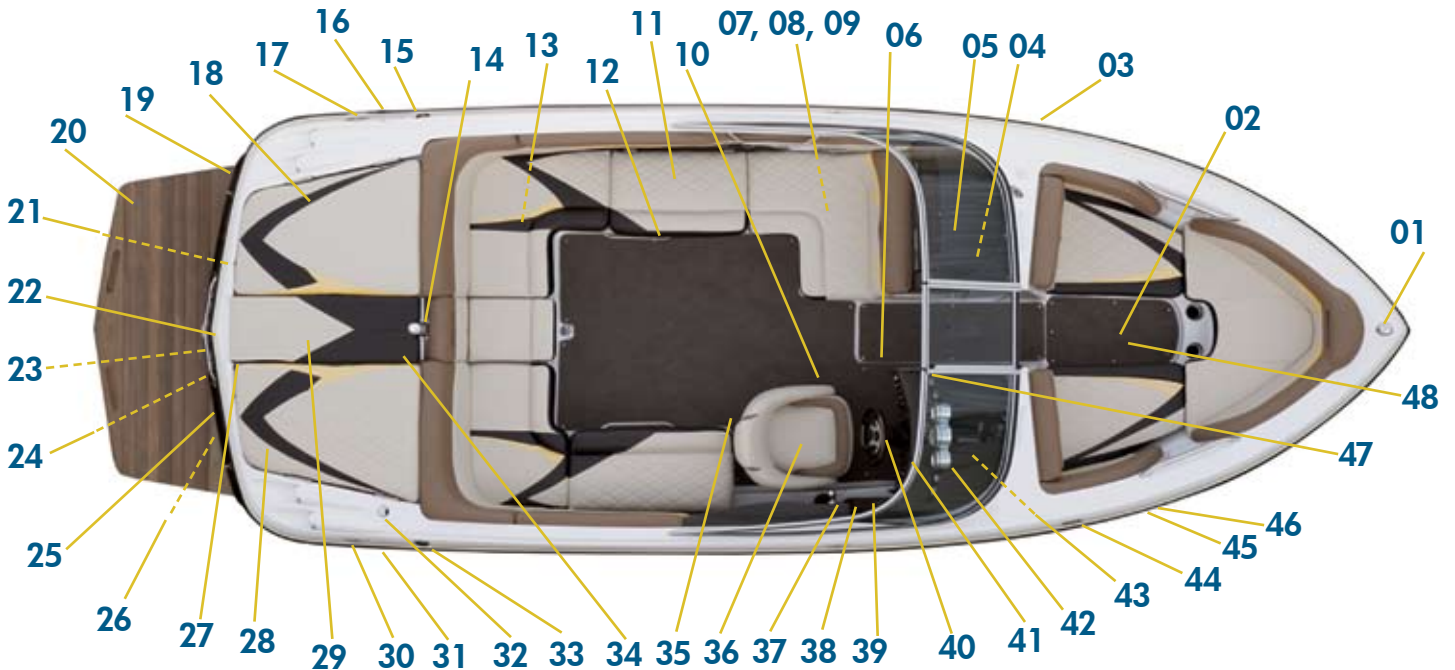

- | | | | |
|----|--|----|---|
| 01 | Bow light | 31 | Bilge thru-hull vent |
| 02 | Bow filler cushion (where equipped) | 32 | Stern light receptacle (if equipped with tower, the light will be in center aft of tower) |
| 03 | Bow cleat | 33 | Fuel tank filler |
| 04 | Stereo CD Player (inside glove box, where equipped); Sirius Satellite Radio (where equipped) | 34 | Automatic fire extinguisher |
| 05 | Glove box | 35 | Subwoofer |
| 06 | Walk-thru seat (where equipped) | 36 | Heated seat (where equipped) |
| 07 | Amp (where equipped) | 37 | Armrest stereo remote |
| 08 | Hand-held fire extinguisher (beneath observer seat) | 38 | Shift/throttle control |
| 09 | Heated observer seat (where equipped) | 39 | iPod interface (where equipped) |
| 10 | Center drain plug | 40 | Steering wheel |
| 11 | Cooler (located under seat) | 41 | Fire suppression unit manual override |
| 12 | Cockpit table mount (where equipped) | 42 | Instrument panel (details elsewhere in this section) |
| 13 | Batteries (including ON-OFF switch) | 43 | Circuit breaker panel (on kick panel beneath instrument panel) |
| 14 | Ski pylon | 44 | Ballast thru-hull vent |
| 15 | Fuel tank filler | 45 | Bilge thru-hull outlet |
| 16 | Ballast thru-hull vent | 46 | Adjustable mirror |
| 17 | Stern cleat | 47 | Bow cleat |
| 18 | Ballast tank located beneath floorboard | 48 | Ballast tank located beneath floorboard |
| 19 | Wake adjustment plate (located under swim platform, where equipped) | | |
| 20 | Swim platform | | |
| 21 | Engine exhaust | | |
| 22 | Transom rail with tow eye | | |
| 23 | Transom drain plug (center beneath swim platform) | | |
| 24 | Under-platform ladder (where equipped) | | |
| 25 | Transom stereo remote (where equipped) | | |
| 26 | Underwater lights (two where equipped under swim platform) | | |
| 27 | Shower wand and switch/Slick Boot wand and switch (where equipped, inside compartment) | | |
| 28 | Ballast tank located beneath floorboard | | |
| 29 | Engine compartment | | |
| 30 | Stern cleat | | |

Boats may also be equipped with towers (standard on X-30), which may include stereo speakers, lights and/or tower-mounted mirror

Storage space is located:

- Under observer's seat
- Under bow seating
- Under aft and wrap-around seating
- Under port and starboard sun pads

MARISTAR 235, X-35

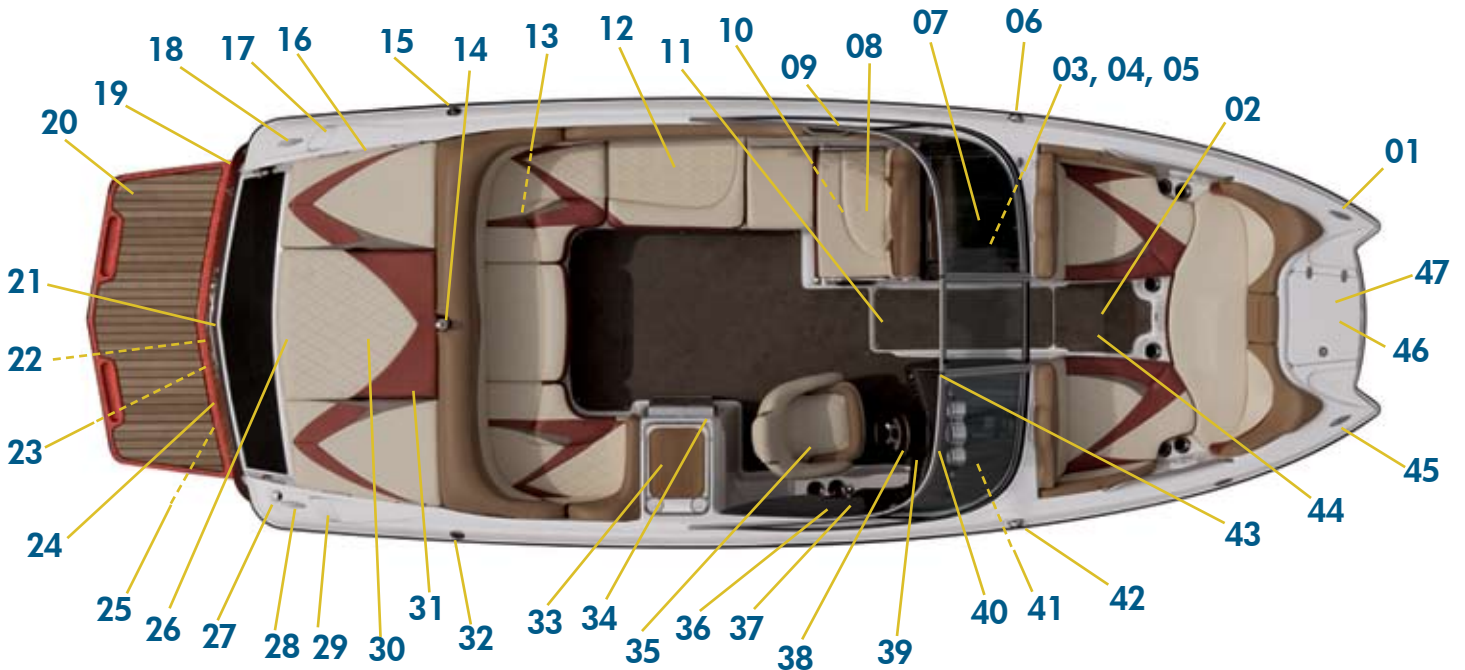

- | | | | |
|----|--|----|--|
| 01 | Bow cleat | 31 | Automatic fire extinguisher |
| 02 | Bow filler cushion (where equipped) | 32 | Fuel tank filler |
| 03 | Stereo CD Player (inside glove box, where equipped); Sirius Satellite Radio (where equipped) | 33 | Sink and shower (where equipped) |
| 04 | Amp (where equipped) | 34 | Upright refrigerator (under sink, where equipped) |
| 05 | iPod interface (where equipped) | 35 | Heated seat (where equipped) |
| 06 | Nav/anchor light | 36 | Armrest stereo remote |
| 07 | Glove box | 37 | Shift/throttle control |
| 08 | Convertible observer's seat | 38 | Steering wheel |
| 09 | Subwoofer (where equipped) | 39 | Fire suppression unit manual override |
| 10 | Hand-held fire extinguisher (beneath observer seat) | 40 | Instrument panel (details elsewhere in this section) |
| 11 | Center drain plug | 41 | Circuit breaker panel (on kick panel beneath instrument panel) |
| 12 | Cooler (located under seat) | 42 | Nav/anchor light |
| 13 | Batteries (including ON-OFF switch) | 43 | Adjustable mirror |
| 14 | Ski pylon | 44 | Ballast tank located beneath floorboard |
| 15 | Fuel tank filler | 45 | Bow cleat |
| 16 | Freshwater tank (in locker, where equipped) | 46 | Ladder |
| 17 | Engine exhaust (two, on top of port and starboard deck near transom) | 47 | Anchor |
| 18 | Stern cleat | | |
| 19 | Wake adjustment plate (located under swim platform, where equipped) | | |
| 20 | Swim platform | | |
| 21 | Transom rail with tow eye | | |
| 22 | Transom drain plug (center beneath swim platform) | | |
| 23 | Under-platform ladder (where equipped) | | |
| 24 | Transom stereo remote (where equipped) | | |
| 25 | Underwater lights (four where equipped under swim platform) | | |
| 26 | Shower wand and switch/Slick Boot wand and switch (where equipped, inside compartment) | | |
| 27 | Stern light receptacle (if equipped with tower, the light will be in center aft of tower) | | |
| 28 | Stern cleat | | |
| 29 | Engine exhaust (two, on top of port and starboard deck near transom) | | |
| 30 | Engine compartment | | |

Boats may also be equipped with towers (standard on X-35), which may include stereo speakers, lights and/or tower-mounted mirror

Storage space is located:

- Under observer's seat
- Under bow seating
- Under aft and wrap-around seating
- Under port and starboard sun pads

MARISTAR 245, X-45

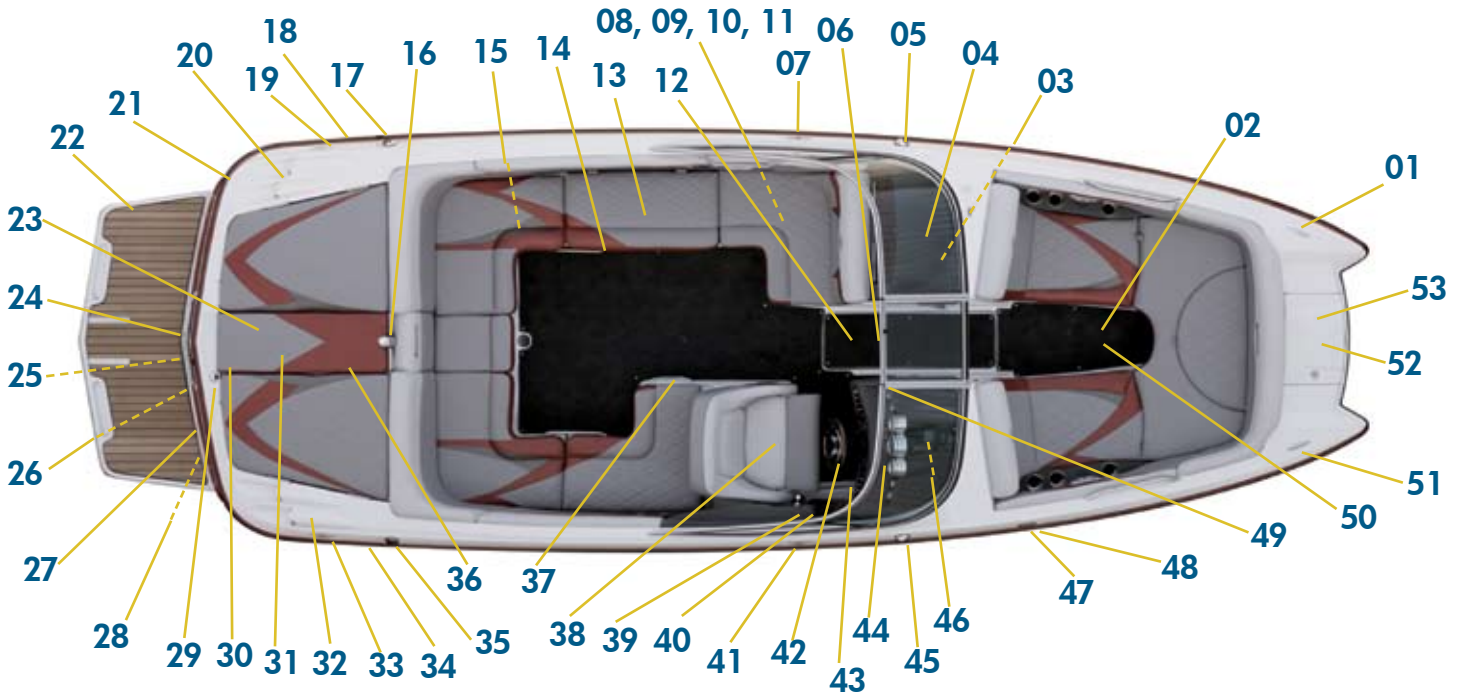

- | | | | |
|----|--|----|--|
| 01 | Bow cleat | 31 | Engine compartment |
| 02 | Bow filler cushion (where equipped) | 32 | Engine exhaust (two, on top of port and starboard deck near transom) |
| 03 | Stereo CD Player (inside glove box, where equipped); Sirius Satellite Radio (where equipped) | 33 | Stern cleat |
| 04 | Glove box | 34 | Bilge thru-hull vent |
| 05 | Nav/anchor light | 35 | Fuel tank filler |
| 06 | Center drain plug | 36 | Automatic fire extinguisher |
| 07 | Midship cleat | 37 | Subwoofer |
| 08 | Amp (where equipped) | 38 | Heated seat (where equipped) |
| 09 | iPod interface (where equipped) | 39 | Armrest stereo remote |
| 10 | Hand-held fire extinguisher (beneath observer seat) | 40 | Shift/throttle control |
| 11 | Heated observer seat (where equipped) | 41 | Midship cleat |
| 12 | Walk-thru seat (where equipped) | 42 | Steering wheel |
| 13 | Cooler (located under seat) | 43 | Fire suppression unit manual override |
| 14 | Cockpit table mount (where equipped) | 44 | Instrument panel (details elsewhere in this section) |
| 15 | Batteries (including ON-OFF switch) | 45 | Nav/anchor light |
| 16 | Ski pylon | 46 | Circuit breaker panel (on kick panel beneath instrument panel) |
| 17 | Fuel tank filler | 47 | Ballast thru-hull vent |
| 18 | Ballast thru-hull vent | 48 | Bilge thru-hull outlet |
| 19 | Stern cleat | 49 | Adjustable mirror |
| 20 | Engine exhaust (two, on top of port and starboard deck near transom) | 50 | Ballast tank located beneath floorboard |
| 21 | Wake adjustment plate (located under swim platform, where equipped) | 51 | Bow cleat |
| 22 | Swim platform | 52 | Ladder |
| 23 | Sun deck filler cushion | 53 | Anchor |
| 24 | Transom rail with tow eye | | |
| 25 | Transom drain plug (center beneath swim platform) | | |
| 26 | Under-platform ladder (where equipped) | | |
| 27 | Transom stereo remote (where equipped) | | |
| 28 | Underwater lights (two where equipped under swim platform) | | |
| 29 | Stern light receptacle (if equipped with tower, the light will be in center aft of tower) | | |
| 30 | Shower wand and switch/Slick Boot wand and switch (where equipped, inside compartment) | | |

Boats may also be equipped with towers (standard on X-45), which may include stereo speakers, lights and/or tower-mounted mirror

Storage space is located:

- Under observer's seat
- Under bow seating
- Under aft and wrap-around seating
- Under port and starboard sun pads

MARISTAR 255, X-55

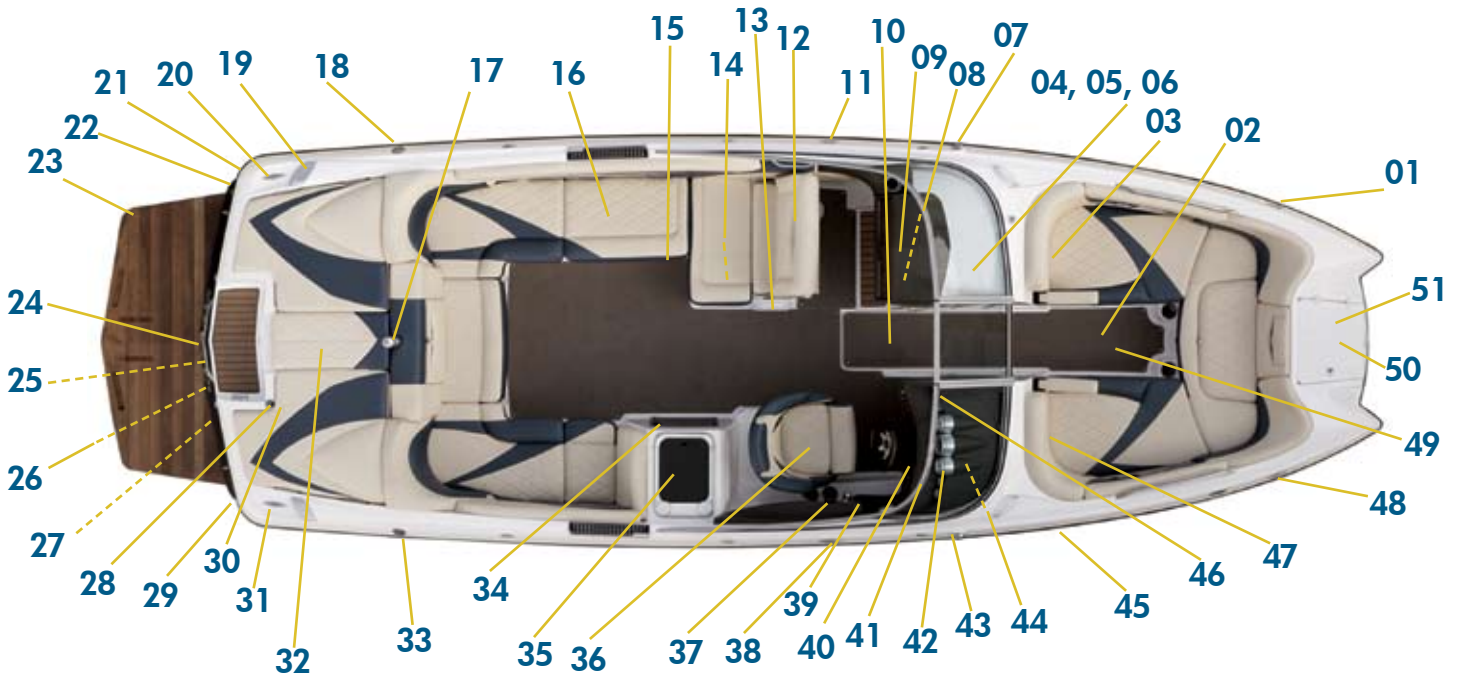

- | | | | |
|----|---|----|--|
| 01 | Bow cleat | 31 | Stern cleat |
| 02 | Bow filler cushion (where equipped) | 32 | Engine compartment |
| 03 | Amp (where equipped) | 33 | Fuel tank filler |
| 04 | Head | 34 | Upright refrigerator (under sink, where equipped) |
| 05 | Hand-held fire extinguisher (beneath observer seat) | 35 | Sink and shower (where equipped) |
| 06 | iPod interface (inside head, where equipped) | 36 | Heated seat (where equipped) |
| 07 | Nav/anchor light | 37 | Armrest stereo remote |
| 08 | Stereo CD Player (where equipped); Sirius Satellite Radio (where equipped) | 38 | Midship cleat |
| 09 | Glove box | 39 | Shift/throttle control |
| 10 | Center drain plug | 40 | Steering wheel |
| 11 | Midship cleat | 41 | Fire suppression unit manual override |
| 12 | Convertible observer seat | 42 | Instrument panel (details elsewhere in this section) |
| 13 | Subwoofer | 43 | Nav/anchor light |
| 14 | Batteries (including ON-OFF switch) | 44 | Circuit breaker panel (on kick panel beneath instrument panel) |
| 15 | Washdown connection | 45 | Holding tank pump-out |
| 16 | Cooler (located under seat) | 46 | Adjustable mirror |
| 17 | Ski pylon | 47 | Amp (standard equipment) |
| 18 | Fuel tank filler | 48 | Bow cleat |
| 19 | Blower exhaust (two, on top of port and starboard deck near transom) | 49 | Ballast tank located beneath floorboard |
| 20 | Stern cleat | 50 | Ladder |
| 21 | Freshwater tank fill | 51 | Anchor |
| 22 | Wake adjustment plate (located under swim platform, where equipped) | | |
| 23 | Swim platform | | |
| 24 | Transom rail with tow eye | | |
| 25 | Transom drain plug (center beneath swim platform) | | |
| 26 | Under-platform ladder (where equipped) | | |
| 27 | Underwater lights (two where equipped under swim platform) | | |
| 28 | Stern light receptacle (if equipped with tower, the light will be in center aft of tower) | | |
| 29 | Freshwater flush port (where equipped) | | |
| 30 | Automatic fire extinguisher | | |

Boats may also be equipped with towers (standard on X-55), which may include stereo speakers, lights and/or tower-mounted mirror

Storage space is located:

- Under observer's seat
- Under bow seating
- Under aft and wrap-around seating
- Under port and starboard sun pads

X-STAR

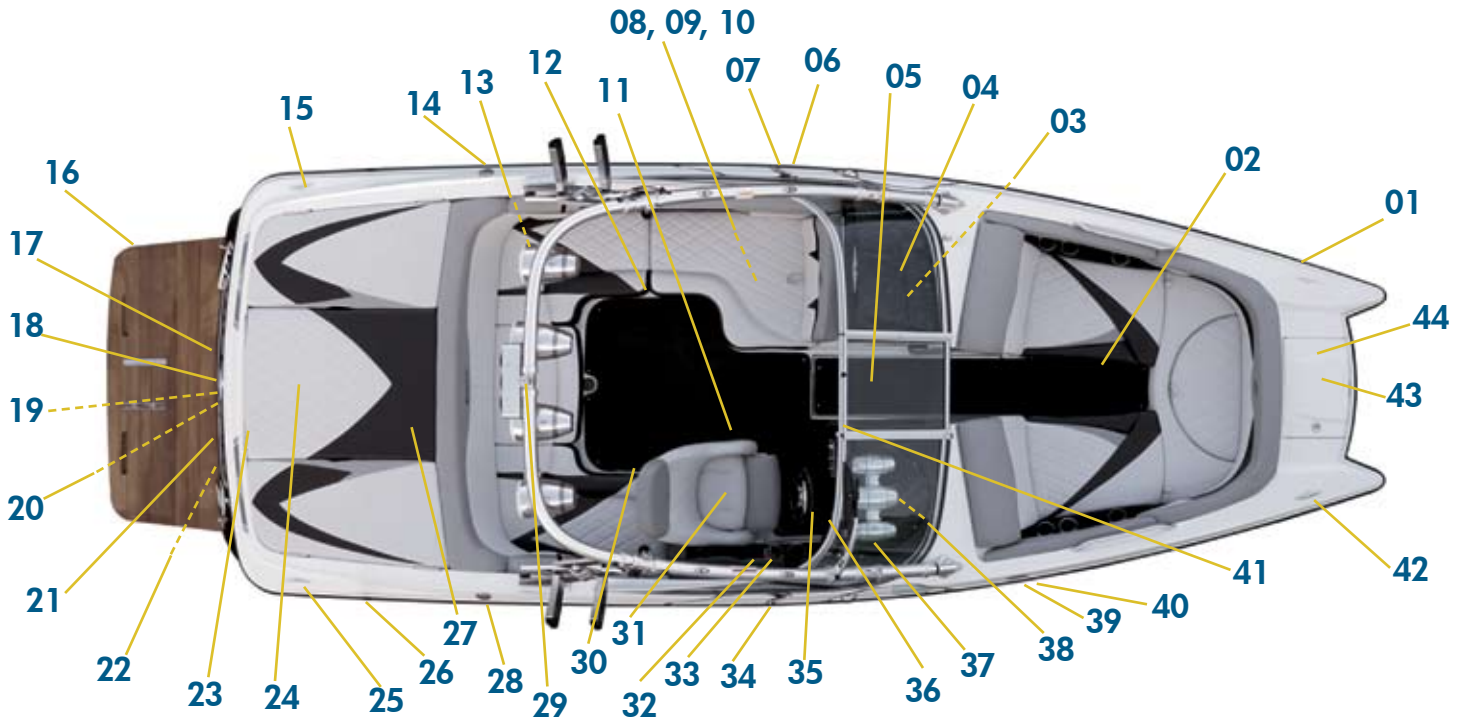

- | | | | |
|----|--|----|--|
| 01 | Bow cleat | 31 | Heated seat (where equipped) |
| 02 | Bow filler cushion (where equipped) | 32 | Armrest stereo remote |
| 03 | Stereo CD Player (inside glove box, where equipped); Sirius Satellite Radio (where equipped) | 33 | Shift/throttle control |
| 04 | Glove box | 34 | Nav/anchor light |
| 05 | Walk-thru seat (where equipped) | 35 | Steering wheel |
| 06 | Ballast thru-hull vent | 36 | Fire suppression unit manual override |
| 07 | Nav/anchor light | 37 | Instrument panel (details elsewhere in this section) |
| 08 | Amp (where equipped) | 38 | Circuit breaker panel (on kick panel beneath instrument panel) |
| 09 | iPod interface (where equipped) | 39 | Ballast thru-hull vent |
| 10 | Hand-held fire extinguisher (beneath observer seat) | 40 | Bilge thru-hull outlet |
| 11 | Center drain plug | 41 | Adjustable mirror |
| 12 | Cockpit table mount (where equipped) | 42 | Bow cleat |
| 13 | Batteries (including ON-OFF switch) | 43 | Ladder |
| 14 | Fuel tank filler | 44 | Anchor |
| 15 | Stern cleat | | Ballast tank located beneath floorboard |
| 16 | Swim platform | | |
| 17 | Engine exhaust | | |
| 18 | Transom rail with tow eye | | |
| 19 | Transom drain plug (center beneath swim platform) | | |
| 20 | Under-platform ladder (where equipped) | | |
| 21 | Transom stereo remote (where equipped) | | |
| 22 | Underwater lights (two where equipped under swim platform) | | |
| 23 | Shower wand and switch/Slick Boot wand and switch (where equipped, inside compartment) | | |
| 24 | Engine compartment | | |
| 25 | Stern cleat | | |
| 26 | Bilge thru-hull pump-out | | |
| 27 | Automatic fire extinguisher | | |
| 28 | Fuel tank filler | | |
| 29 | Nav/anchor light | | |
| 30 | Subwoofer | | |

Boat is also be equipped with a tower, which may include stereo speakers, lights and/or tower-mounted mirror

Storage space is located:

- Under observer's seat
- Under bow seating
- Under aft and wrap-around seating
- Under port and starboard sun pads

MARISTAR 280, X-80

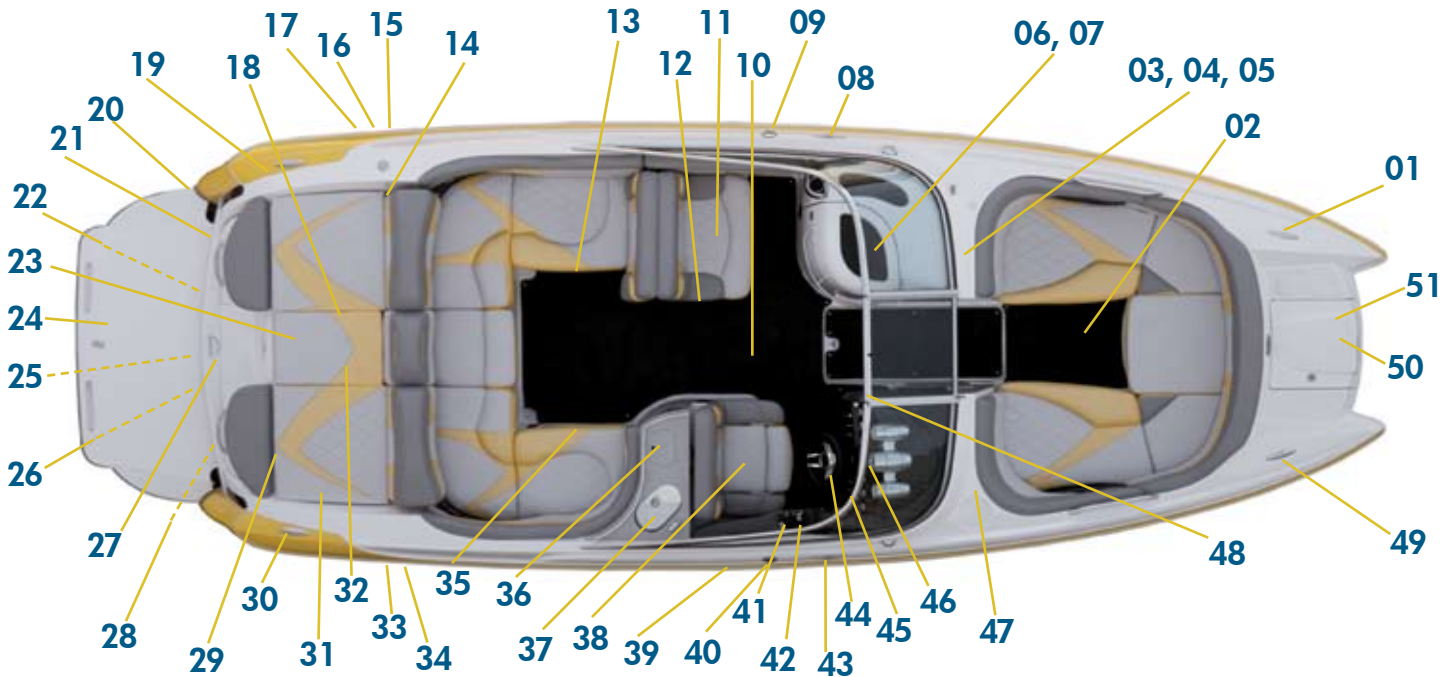

- | | | | |
|----|--|----|--|
| 01 | Bow cleat | 31 | Automatic fire extinguisher |
| 02 | Bow filler cushion (where equipped) | 32 | Engine compartment |
| 03 | Amp (where equipped) | 33 | Bilge thru-hull outlet |
| 04 | iPod interface (inside head, where equipped) | 34 | Fuel tank filler |
| 05 | Stereo CD Player (where equipped); Sirius Satellite Radio (where equipped) | 35 | Refrigerator drawer (under seating, where equipped) |
| 06 | Head | 36 | Entertainment unit (under sink, where equipped) |
| 07 | Hand-held fire extinguishers (beneath observer seat) | 37 | Freshwater tank, sink and shower (where equipped) |
| 08 | Midship cleat | 38 | Heated seat (where equipped) |
| 09 | Nav/anchor light | 39 | Thru-hull pump-out |
| 10 | Center drain plug | 40 | Nav/anchor light |
| 11 | Convertible observer seat | 41 | Armrest stereo remote |
| 12 | Subwoofer | 42 | Shift/throttle control |
| 13 | Cockpit table mount (where equipped) | 43 | Midship cleat |
| 14 | Batteries (including ON-OFF switch) | 44 | Steering wheel |
| 15 | Thru-hull pump-out | 45 | Fire suppression unit manual override |
| 16 | Holding tank pump-out (where equipped) | 46 | Instrument panel (details elsewhere in this section) |
| 17 | Fuel tank filler | 47 | Circuit breaker panel (on kick panel beneath instrument panel) |
| 18 | Stern light receptacle | 48 | Adjustable mirror |
| 19 | Stern cleat | 49 | Bow cleat |
| 20 | Dual trim tabs | 50 | Ladder |
| 21 | Freshwater tank fill | 51 | Anchor |
| 22 | Engine exhaust (two under swim platform) | | Ballast tank located beneath floorboard |
| 23 | Sun deck fill cushion | | |
| 24 | Swim platform | | |
| 25 | Transom drain plug (center beneath swim platform) | | |
| 26 | Under-platform ladder (where equipped) | | |
| 27 | Ski pylon | | |
| 28 | Underwater lights (two where equipped under swim platform) | | |
| 29 | Shower wand and switch/Slick Boot wand and switch (where equipped) | | |
| 30 | Stern cleat | | |

Boats may also be equipped with towers (standard on X-80), which may include stereo speakers, lights and/or tower-mounted mirror

Storage space is located:

- Under observer's seat
- Under bow seating
- Under aft and wrap-around seating
- Under port and starboard sun pads

CSX 220

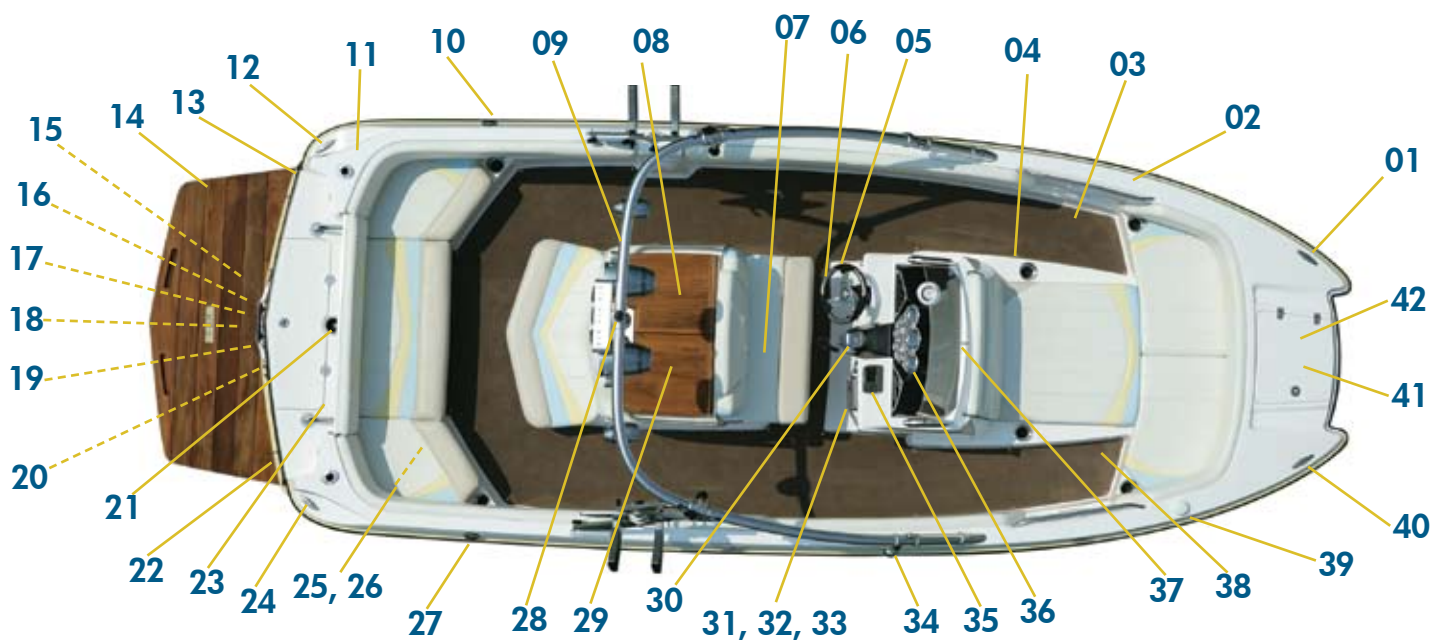

- | | | | |
|----|---|----|--|
| 01 | Bow cleat | 31 | Amp (where equipped) |
| 02 | Sirius Satellite Radio antenna (where equipped) | 32 | Subwoofer (where equipped) |
| 03 | Bow filler cushion (where equipped) | 33 | iPod interface (where equipped) |
| 04 | Circuit breaker panel | 34 | Stereo CD Player (where equipped); Sirius Satellite Radio (where equipped) |
| 05 | Steering wheel | 35 | Nav/anchor light |
| 06 | Hand-held fire extinguisher (under helm) | 36 | Instrument panel (details elsewhere in this section) |
| 07 | Center drain plug (beneath seating) | 37 | Windshield-mounted mirror |
| 08 | Engine compartment and seacock (sea strainer) access | 38 | Bow filler cushion (where equipped) |
| 09 | Fire port | 39 | GPS antenna |
| 10 | Fuel tank filler | 40 | Bow cleat |
| 11 | Freshwater tank fill | 41 | Bow ladder |
| 12 | Stern cleat | 42 | Anchor |
| 13 | Freshwater flush port | | |
| 14 | Swim platform | | |
| 15 | Blower exhaust (two, under swim platform) | | |
| 16 | Under-platform ladder (where equipped) | | |
| 17 | Telescopic, removable dive ladder (where equipped) | | |
| 18 | Zinc anode bonding system (under swim platform) | | |
| 19 | Transom drain plug (center, beneath swim platform) | | |
| 20 | Underwater lights (four, where equipped, under swim platform) | | |
| 21 | Ski pylon | | |
| 22 | Transom stereo remote (where equipped) | | |
| 23 | Slick Boot wand and switch (where equipped) | | |
| 24 | Stern cleat | | |
| 25 | Batteries (including ON-OFF switch) | | |
| 26 | Battery circuit breaker panel | | |
| 27 | Fuel tank filler | | |
| 28 | Anchor light | | |
| 29 | Shower, sink and cooler access; shower wand and switch | | |
| 30 | Shift/throttle control | | |

Boats may be equipped with towers, which include a storage box, red & white dome lights, navigation lights, and may also have cockpit floodlights and/or Xtreme mirror

Storage space is located:

- Under bow seating
- Under aft seating

INSTRUMENT PANELS



ProStar 190, ProStar 197, X-1, X-7, ProStar 214, X-14, 214V, X-14V

Top row of gauges from left:

Oil pressure gauge
Engine temperature gauge
Speedometer
Multi-function/tachometer
Speedometer or Perfect Pass
Voltmeter
Fuel gauge

Lower left panel:

Horn
Seat Heat switch
Heater switch
Courtesy lights switch

Lower right panel:

Speedo adjustment switch
Nav/anchor lights switch
Bilge pump switch
Blower switch
Ignition key slot

X-Star, MariStar 280, X-80

Top row of gauges from left:

Tachometer
Speedometer
Video display gauge

Middle left panel:

Oil pressure gauge
Engine temperature gauge

Middle right panel:

Voltmeter
Fuel gauge

Lower left panel:

Horn
Courtesy lights switch
Shower switch
Heater switch
Ballast port switch
Ballast KGB switch
Ballast starboard switch

Lower right panel:

Tower light switch
Blower switch

Bilge pump switch
Nav/anchor lights switch
Ignition switch

MariStar 200, MariStar 215, MariStar 230, MariStar 245, X-2, X-15, X-30, X-45

Top row of gauges from left:

Oil pressure gauge
Engine temperature gauge
Video display gauge (where equipped)
Speedometer
Perfect Pass (option)
Fuel gauge
Voltmeter

Lower left panel:

Horn
Seat heat switch
Heater switch
Wash down switch
Courtesy lights switch
12-volt receptacle

Lower right panel:

Display selector switch
Nav/anchor lights switch
Forward bilge switch
Aft bilge switch
Blower switch
Ignition key slot

MariStar 235, X-35, 255, X-55

Top row of gauges from left:

Oil pressure gauge
Engine temperature gauge
Tachometer gauge
Speedometer with display
Unused billet filler
Fuel gauge
Voltmeter

Top row of gauges from left with optional

Video Display:
Oil pressure gauge
Engine temperature gauge
Tachometer gauge
Video Display Screen
Speedometer gauge
Fuel gauge
Voltmeter

Lower left panel:

Horn
Seat Heat switch
Heater switch
Wash down switch
Courtesy lights switch
12-volt receptacle

Lower right panel:

Display "Disp" switch
(on Video Display Screen-equipped, dash dimmer)
Nav/anchor lights switch
Forward bilge switch
Aft bilge switch
Blower switch
Ignition key slot

CSX 265

Gauge panel upper:

Port engine tachometer
Video display gauge
Starboard engine tachometer

Gauge panel lower:

Port engine multiple gauge: gas (upper left); voltmeter (upper right); engine temperature (lower left); oil pressure (lower right).
Starboard engine multiple gauge: gas (upper left); voltmeter (upper right); engine temperature (lower left); oil pressure (lower right).

Switch panel, upper row:

Navigation/anchor light switch
Courtesy light switch
Tower light switch, foreward
Tower light switch, aft

Switch panel, lower row:

Three (3) bilge switches
Blower switch
Engine hatch switch

CSX 220

Upper panel:

Tachometer
Speedometer
Perfect Pass (option)
Display selector (multi-purpose gauge)
Starboard switch: speedometer calibration
Engine temperature gauge
Oil temperature gauge
Voltmeter
Fuel gauge

Port side switches, top row from left:

Navigation/anchor light switch
Forward/aft tower light switch
Courtesy light switch

Port side switches, bottom row from left:

Forward bilge auto/manual switch
Aft bilge auto/manual switch
Freshwater switch
Up/down motor box hatch actuator switch
On/off bilge blower switch

Center switches:

Port ballast system fill/empty switch
KGB ballast system fill/empty switch
Starboard ballast system fill/empty switch

Starboard side console:

Glovebox
Garmin GPS/chartplotter/sounder (optional)
Clarion stereo AM/FM radio and CD player (optional)
12-volt courtesy outlet
MP3/iPod input

Below steering helm:

Emergency engine safety switch
Ignition switch

MEASUREMENTS

ProStar 190

Length of Boat 19'8"
 Width Amidship.....91"
 Boat Weight.....2,620 lbs.
 Length of Boat w/Platform..... 21'6"
 Towing Length.....22"
 Towing Width..... 100"
 Fuel Capacity.....28 gallons
 Total Weight Capacity
 7 people or 1,087 lbs.

ProStar 197, X-7

Length of Boat 19'8"
 Width Amidship.....91"
 Boat Weight.....2,800-3,070 lbs.
 Length of Boat w/Platform..... 21'6"
 Towing Length.....22'
 Towing Width..... 100"
 Fuel Capacity.....28 gallons
 Total Weight Capacity
 7 people or 1,087 lbs.

ProStar 214, X-14

Length of Boat 21'4"
 Width Amidship.....96"
 Boat Weight.....3,100-3,300 lbs.
 Length of Boat w/Platform..... 23'8"
 Towing Length.....24"
 Towing Width..... 100"
 Fuel Capacity.....40 gallons
 Total Weight Capacity
 11 people or 1,525 lbs.

ProStar 214V, X-14V

Length of Boat 21'4"
 Width Amidship.....96"
 Boat Weight.....3,400 lbs. est.
 Length of Boat w/Platform..... 23'8"
 Towing Length.....24'
 Towing Width..... 100"
 Fuel Capacity.....34 gallons
 Total Weight Capacity
 11 people or 1,450 lbs.

X-1

Length of Boat 20'7"
 Width Amidship.....90"
 Boat Weight.....3,200 lbs.
 Length of Boat w/Platform..... 22'6"
 Towing Length.....22'3"
 Towing Width.....96"
 Fuel Capacity.....33 gallons
 Total Weight Capacity
 11 people or 1,615 lbs.

MariStar 200, X-2

Length of Boat20'
 Width Amidship.....96"
 Boat Weight.....3,350-3,500 lbs.
 Length of Boat w/Platform..... 22'1"
 Towing Length.....22'9"
 Towing Width..... 100"
 Fuel Capacity.....45 gallons
 Total Weight Capacity
 11 people or 1,609 lbs.

MariStar 215, X-15

Length of Boat 21'8"
 Width Amidship..... 100"
 Boat Weight.....3,425-3,575 lbs.
 Length of Boat w/Platform..... 23'9"
 Towing Length.....24'1"
 Fuel Capacity.....45 gallons
 Total Weight Capacity
 14 people or 2,325 lbs.

MariStar 230, X-30

Length of Boat 22'5"
 Width Amidship..... 102"
 Boat Weight.....3,900-4,120 lbs.
 Length of Boat w/Platform..... 24'8"
 Towing Length.....24'
 Fuel Capacity.....60 gallons
 Total Weight Capacity
 16 people or 2,475 lbs.

MariStar 235, X-35

Length of Boat 23'5"
 Width Amidship..... 102"
 Boat Weight.....4,650-4,900 lbs.
 Length of Boat w/Platform..... 25'3"
 Towing Length.....25'8"
 Fuel Capacity.....60 gallons
 Total Weight Capacity
 16 people or 2,400 lbs.

MariStar 245, X-45

Length of Boat 24'2"
 Width Amidship..... 102"
 Boat Weight.....4,730-4,950 lbs.
 Length of Boat w/Platform..... 26'4"
 Towing Length.....26'1"
 Towing Width..... 100"
 Fuel Capacity.....90 gallons
 Total Weight Capacity
 18 people or 2,928 lbs.

MariStar 255, X-55

Length of Boat 25'5"
 Width Amidship..... 102"
 Boat Weight.....4,850-5,000 lbs.
 Length of Boat w/Platform..... 27'8"
 Towing Length.....31'2"
 Fuel Capacity.....90 gallons
 Total Weight Capacity
 18 people or 3,000 lbs.

X-Star

Length of Boat 24'9"
 Width Amidship..... 100"
 Boat Weight.....4,250 lbs.
 Length of Boat w/Platform..... 24'6"
 Towing Length.....24'
 Towing Width..... 100"
 Fuel Capacity.....57 gallons
 Total Weight Capacity
 12 people or 1,770 lbs.

MariStar 280, X-80, 280 STS

Length of Boat 28'3"
 Width Amidship..... 114"
 Boat Weight.....6,200 lbs./6,420 lbs.
 Length of Boat w/Platform..... 28'3"
 Towing Width..... 114"
 Fuel Capacity.....100 gallons
 Total Weight Capacity
 Yacht certified; no capacity rating

CSX 220

Length of Boat 21'5"
 Width Amidship..... 102"
 Boat Weight.....4,300 lbs.
 Length of Boat w/Platform..... 23'7"
 Fuel Capacity.....46 gallons
 Total Weight Capacity
 12 people or 1,595 lbs.

CSX 265

Length of Boat 26'5"
 Width Amidship..... 114"
 Boat Weight.....7,750 lbs.
 Length of Boat w/Platform..... 29'2"
 Fuel Capacity.....125 gallons
 Total Weight Capacity
 Yacht certified; no capacity rating

In calculating the amount of weight, you must also take into consideration the weight of the gasoline and any ballast added. The weight of gasoline is approximately 5.8 to 6.5 pounds (U.S.) per gallon, depending upon the weather and other factors, including the addition of ethanol, which is slightly denser and will add very slightly to the overall weight. Water pumped into the ballast system will add 8.3 pounds (U.S.) for every gallon added.

Overloading a boat may cause it to become unstable and may potentially result in the boat's flotation system becoming overwhelmed. Too much weight can sink any boat! Within this Manual and on a label mounted in each boat, except in the 280 and 265 models, is the weight limit for that specific model. Bear in mind that total weight limits include water ballast, gear brought onto the boat, additional options and all people. Equally critical is how weight is distributed throughout the boat. If too much weight is placed in one area it can have serious impact on maintaining control. Items and people can also shift positions during operation, potentially causing a dangerous situation.

INSTRUMENT GAUGES AND SWITCHES



Proper control of MasterCraft boats extends beyond the steering wheel. Each boat is equipped with multiple gauges that provide information to guide the operator in maintaining control. There are also a variety of switches and buttons within the boat that control various functions from comfort to watersports enhancement to safety-related features. It is important for the boat owner and/or operator to become familiar with all gauges and switches in the boat, the functionality of each, and how to respond to alarms and warnings that the instrument panel may provide.

In the *Guide to Individual Models* section of this Owner's Manual is a listing of the locations of gauges and switches for the various model instrument panels. Operators should match up these listings with the actual panel. Prior to boating, owners and operators should also review and understand the following section regarding the boat's electrical components and operations through the battery or batteries, as well as the circuit breaker system. A thorough understanding of these systems is critical to avoiding potential issues that may arise during an outing.

The following is an explanation of the functionality of the gauges and switches that are listed for the various models.



12-Volt Receptacle (All Models; Some May Have Multiple Receptacles)

MasterCraft boats have one (1) or more 12-volt receptacles. Examine your boat to determine whether there are additional outlets. Prior to plugging any accessory into a 12-volt receptacle, ensure that the device is designed for use when connected to a 12-volt receptacle and will not be damaged by the connection to the receptacle.



Accessory Switches (All Models—Actual Switch Usage Will Vary)

Instrument panels may be equipped with Accessory Switches. In some instances, the indicator may be labeled with the name of the accessory, such as "Heater." Accessory switches are two-position or three-position switches. Toggling will turn a connected accessory ON and OFF.



Aft Light Switch (Models Equipped with Optional Tower Lights)

The location of the aft light switch (where equipped) will vary by model and should be located by the operator. In some instances, there may be two (2) switches. In all instances, the lights operate by using two-position switches, one position for ON and the other for OFF.



AM/FM Stereo, CD Player, Remote Control, iPod and MP3 Player Connections

(Stereo Standard Installation on X-Series; Optional on All Other Models; Remote Control on Armrest, iPod and MP3 Player Connections with Stereo Installation)

Boats may be equipped with a range of entertainment opportunities from radios and CD players to connections for personal devices. ALL radio and CD players will be located within the glovebox of the boat. Remotes may be in the armrest or on the transom.

The iPod interface option features a cable located inside the glovebox that allows the unit to simply be plugged in and run off the boat's electrical system. An optional plug-in location for MP3 players is available. Be aware that all such devices are a drain on the boat's battery and electrical system. Care should be taken to avoid excessive usage of such devices and by responding to any alarms that sound so that the boat's battery(ies) does not become fully discharged.

Another option is a wireless stereo remote that will float if accidentally dropped overboard. The remote can also double as a key fob for a limited number of keys.

The stereo and components come with a separate manual explaining operation of the devices. Please review and become familiar with the equipment.



Attitude Adjustment or Trim Tab Switch (All MariStars and CSX 265)

MasterCraft utilizes Lenco attitude adjustment plate kits on several models. Dual plate kits are available on the MariStar 280, X-80, 280 STS and CSX 265 models; a single plate kit is used on the MariStar 200, X-2, 215, X-15, 230, X-30, 235, X-35, 245 and X-45. On the dual attitude adjustment plate system, the plates operate independently of each other to provide optimal performance by redirecting water flow near the transom of the boat. These plates have been designed to improve the overall attitude of a boat. If used properly, the plates will improve the ride, reduce drag, increase speed and improve the fuel efficiency of the boat.

The operation of the attitude adjustment plates is basic. The plate or plates are mounted with the actuator(s) on the transom of the boat. When the plate(s) is/are lowered, the water flow is redirected, creating an upward force at the stern of the boat. When the stern rises, the bow will lower.

Since these actuators are electromechanical, they provide an immediate response at the touch of the switch. The switch adjustments are based on the position of the bow. On the dual attitude adjustment plate system, the right side of the switch controls the starboard plate

and the left side of the switch controls the port plate. On the single plate system, there is only one switch control.

The system is set up this way to minimize the guesswork while underway. To lower the starboard bow, press the right (starboard) switch where it reads DOWN. To lower the port bow, press the left (port) switch where it reads DOWN. On the single plate system, press DOWN.

Since our models have different weights, lengths, speed and performance, it will take some practice for the operator to understand how your boat reacts with the attitude adjustment plates installed. The plates will allow your boat to get on plane faster and continue planing at lower speeds. This will improve visibility and the overall safety of your boat. **When making adjustments with the attitude adjustment plates, use short momentary taps of the switch.** Continued practice will help you become familiar with how the plates perform.

Special Conditions

Head Sea: Lower both plates by tapping slightly BOW DOWN on both sides of a dual system, BOW DOWN on a single system. This will bring the bow down while maintaining speed. This also allows the hull of the boat to absorb the impact of the waves. This adjustment will result in a more efficient and smoother ride. Changes should be made in small increments to ensure maintaining control of the boat.

Following Sea: Make sure the plates are fully retracted by pressing BOW UP on both sides of a dual system, and BOW UP on a single system. This will bring the plate(s) up to a fully retracted position, decreasing lift in the stern and allowing the bow to rise. If the plate(s) is/are deployed, the bow may dig.

Windy Chop: To raise the windward side of the boat on dual systems, press BOW UP on that side. If this is not sufficient press BOW DOWN on the leeward side of the boat. Do not over-trim when attempting this. This will allow the windward side of the boat to rise and will minimize spray.

Shallow Water/Hole Shot: Lower both plates completely on a dual system by pressing BOW DOWN on both sides (the single plate on a single system). This provides lift in the stern of the boat and will keep the bow down. As you throttle up and speed increases, raise the tab(s) by pressing BOW UP on both sides of a dual system, and BOW UP on the single system.

Uneven Load: When equipped with a dual system, if one side of the boat is higher than the other while running, press BOW DOWN on the switch on that side. This will lower the tab on the listing side (low side) to bring the boat level.

Porpoising: To stop porpoising, press BOW DOWN on both sides of a dual plate system, BOW DOWN on a single system. The plate(s) needs only to be deployed slightly to correct this adverse situation.



While operating attitude adjustment plates use caution. Improper use of plates can cause accidents, which may result in serious injury or death.

While the boat is underway do not move one plate up or down significantly as this may cause listing.

While at higher speeds do not over-trim, as this will cause the bow to lower quickly, resulting in a reduction of speed and may cause the boat to veer.

When in following seas or when running an inlet, the plates should be fully retracted. This will allow for optimal performance.

ELECTROMECHANICAL ACTUATORS PROVIDE AN INSTANT RESPONSE. WHEN MAKING ADJUSTMENTS, USE SHORT MOMENTARY TAPS OF THE SWITCH.



Ballast Empty/Fill Switches (On Ballast-equipped Models Only)

On boat models equipped with a ballast system, a separate three-position switch will allow for the filling or emptying of the ballast tanks and/or bags. **Be aware that the engine must operate at 1500 RPM during the fill and empty processes.** Check engine specifications for related engine idle speed, which may be too low for the empty/fill operation to be properly accomplished; it is likely that the boat will need to be in motion during the filling and emptying of the ballast system. Failure to increase engine RPM to the required level may result in malfunction or permanent damage to the ballast pumps that force the water through the system. Such damage is not covered under your warranty. The ballast controls vary in location by model, and the operator should determine exact location prior to use. The three-position switches are clearly marked; FILL, OFF (in center), and EMPTY.

An LED light is in the tip of each switch. At the conclusion of the FILL process, the light will blink six times in succession, pause for two-to-three seconds, and then blink an additional six times. This signals that the FILL process is complete. If the system senses any potential problems, the LED lights may blink from one to five times (each signifies individual issues). If this occurs, see an authorized MasterCraft dealer for analysis and correction. Do not attempt to correct the issue on your own or continue to FILL the ballast as it may result in damage to the system.



Manual and Automatic Bilge Pump Switch (All Models)

The bilge pumps on all V-drive models will be in the automatic mode when the ignition key is turned ON. Some models may have two (2) switches, one for the forward bilge and one for the aft. In these instances, the switches will be marked. The manual and automatic bilge discharge system is never completely off. When in the automatic (default) position, a sensor alerts the system to discharge water from the bilge area. Boat operators are advised to leave the switch in the automatic position, unless there appears to be excess water in the bilge. In that event, the bilge pump can be manually activated by turning the bilge pump switch to the

manual ON position. Return the switch to the automatic position when finished emptying the bilge. Leaving the switch in manual mode can result in damage to the pump and may not be covered by warranty!



Blower Switch

(All Models)

A two-position switch activates the engine box ventilation blower. Push the top half of the switch to turn the blower ON.

Note: The blower must operate for a minimum of four (4) minutes before starting the engine at any time. The

blower must also be operated during idle and slow-speed running, but is not necessary during cruising speed.



To prevent a possible explosion, operate the blower for at least four (4) minutes before starting the engine and always when at idle or slow-running speed. Explosive gasoline and/or battery fumes may be present in the engine compartment. Failure to operate the blower as instructed may cause improper ventilation of the boat engine and bilge areas, and fuel vapors can accumulate in this area, causing a fire or explosion which may result in death or serious injury!



Circuit Breakers

(All Models)

All major boat circuits are protected from shorting and overload by re-settable circuit breakers. If a problem develops with one of the following circuits, switch OFF the circuit and wait for approximately one (1) minute. Then fully push the appropriate breaker button and switch ON the circuit. If the circuit continues to trip, there is a problem somewhere that must be attended to immediately. See your

authorized MasterCraft service department to resolve this matter.

The location of the main circuit breaker board is under the dash panel. In some models, there is an additional breaker panel to assist with the accessory load, and where equipped is located near the battery box. There may also be a waterproof fuse for the stereo amplifier, where equipped. If the boat's accessories are malfunctioning, check and then re-set breakers as necessary.

The engines are also equipped with breaker systems. The main 35A circuit breaker protects the engine electrical system and components from overload. If the engine will not turn over with the battery switch in the ON position, locate the red breaker re-set button (labeled "35") in the engine. There will be an audible click. Try again to start the engine. If the breaker trips again, the engine requires attention. Immediately take your boat to your authorized MasterCraft service department.

In addition to the 35A circuit breaker, the engines are equipped with additional component overload protection, including a 15A ATO fuse for the fuel pump, a 15A ATO fuse for the injectors and a 15A ATO fuse for the ECM unit.

If you suspect that any of these fuses may not be operating as designed, you should take your boat to your authorized MasterCraft service department for inspection and repair.

If during maintenance or inspection it becomes necessary to remove or re-position any of the engine's wiring or wire harness(es) verify that the wiring has been returned to its original position and that all harnesses are routed correctly before attempting to use the boat again. If a wiring clip or retainer breaks, replace it immediately. Wiring is specifically routed to eliminate problems related to engine heat and spray or immersion in liquids. Electrical problems may result if wiring is moved from its original position!



Courtesy Lights Switch

(All Models)

This switch is a two-position switch that activates the courtesy lights within the boat. Turning the switch upwards will turn the lights ON, and turning it downwards will turn the lights OFF.

Note that on boats equipped with the optional underwater lights (transom below the water line), this same switch operates those lights. **Also note that the underwater lights should never be operated unless the boat is in the water. Even though these are L.E.D. lights, they generate some heat and require the cooling effect of the water to avoid premature burn-out of the bulb.**



Cruise Control Gauge

(Where Equipped)

Boats equipped with cruise control systems come with short manuals that describe how to operate and maintain the cruise control system. Refer to the appropriate manual prior to operation of the system.

Boats featuring the "simple" cruise system function the same as an automobile with an ON/OFF switch and +/- to increase or decrease speed. For boats equipped with dual engines, see also the *Engine Synchronizing Switch* instructions of this section. The engine synchronizing switch must be ON for the cruise to work on dual-engine boats. Also review the operating instructions from the cruise control provider.



Display Selector Switch

(ProStar 190, ProStar 197, X-7)

On the models equipped with the Multi-Function gauge, this switch allows the operator to toggle between functions.



Dual Battery Operation Switch

(All MariStar Models and Similar X Series, X-Star, CSX 220, CSX 265)

MariStar and X-Star: For normal operation the battery switch should be placed in the ON position. This allows the engine and all accessories to receive power. The engine will recharge both batteries with the switch ON. For transportation and storage, the battery switch should be placed in the OFF position to allow both batteries to be isolated from all circuits.

Note: The switch knob may be removed when it is in the OFF position. This is a security feature.

If the engine will not start because the battery is discharged, the engine may be started from the house battery by placing the switch in the COMBINE BATTERIES position. After the engine is started, the switch should be returned to the ON position and NOT allowed to remain in the COMBINE Batteries mode.

MariStar 280 and X-80: For normal operation the port and starboard battery switches should be placed in the ON position. The COMBINE BATTERIES switch should remain OFF. The engine and all accessories will receive power.

Note: The port battery is a dedicated start battery for the port engine and the starboard battery provides starting current of the starboard engine while also providing power for accessory circuits. For transportation and storage, all battery switches should be placed in the OFF position to isolate both batteries from all circuits.

NOTE: The switch knob may be removed when it is in the OFF position. This is a security feature.

If either battery becomes discharged, start the engine with the remaining charged battery and THEN set the COMBINE BATTERIES switch to ON. The remaining engine may then be started. Return the COMBINE BATTERIES switch to OFF. The COMBINE BATTERIES switch should NOT be left ON.

CSX 220 and 265: The CSX 220 and CSX 265 are equipped with dual batteries. One battery is reserved to provide engine-starting power and the other provides power for all electrical accessories. These batteries are located under the starboard rear seat cushion. To facilitate access, the batteries are mounted on a sliding tray, which is secured with a pin. Remove the pin to slide the tray forward for battery maintenance.

Outside this compartment, located on the side of the deck under the starboard seat is the battery switch box. For normal operation of the boat, the switch should be set to ON. For transportation and storage, the switch should be moved to OFF. In the event of a failure of the starter battery, the two batteries may be combined to provide additional power to start the engine. This can be done by setting the battery switch to COMBINE BATTERIES and starting the engine as normal. After the engine is started, the switch should be returned to the ON position.

The battery charger inlet connector is also located in the battery switch box. Please see information provided by the charger manufacturer. Battery chargers installed by MasterCraft are of the charger/maintainer variety. The charger may be left connected to the batteries indefinitely.

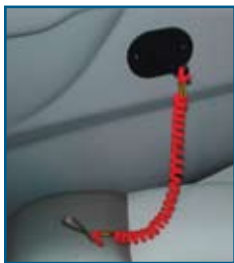

Engine Emergency Safety Stop Switch (All Models)

The engine emergency safety stop switch, which is attached to the lanyard, is an ignition cut-off switch designed to stop the engine in the event the operator is thrown or moves too far away from the helm.

The lanyard is equipped with a hook on one end that should be attached to your clothing or PFD, and the opposite end has a slide that fits over the ignition switch. Be sure that the slide is firmly attached to the ignition switch before starting.

The ignition switch is located near the throttle control box, the armrest or on the instrument panel. If the slide is left off or is loose, the engine will crank but will not start. **Operators should NEVER attempt to override this safety system!**



The safety switch lanyard must be attached to the operator whenever the engine is running. Failure to do so may result in death or serious injury!



Engine Hatch Switch (MariStar 280IX-80, CSX-220, CSX-265)

Where equipped, an engine hatch cover switch allows the cover to open and close electronically. The three-position switch is pressed up to open and down to close the hatch.



The engine box serves as a machinery guard. The engine must be OFF whenever the box is open. Clothing or body parts can get caught in moving parts, causing death or serious injury. Keep away from moving parts!



Engine Oil Pressure Gauge (All Models)

The engine oil pressure gauge indicates the pressure of the lubricating oil inside the engine. The average pressure ranges are between six (6) pounds per square inch (PSI) at 1000 RPM to 40 PSI or more at cruise-range speeds. A reading of pressure below 5 PSI at 1000 RPM may be caused by a low oil level or other potentially serious problems that result in low oil pressure. **If you experience low oil pressure, stop your engine immediately and check your oil level before operating again.**



Do not continue to run the engine if the oil pressure is low. If you do, the engine may become so hot that it, or surrounding components, could catch fire. You or others could be burned and the boat seriously damaged. Check your oil level and add an appropriate amount of approved motor oil before operating again or have your boat serviced by your local authorized dealer's service department. Note that damage to your engine from inappropriate oil levels can be costly to repair. Such damage is not covered by your warranty.



Engine Synchronizing Switch (MariStar 280, X-80 and CSX 265)

This two-position switch allows the engines to operate in synchronization. **Do not engage the switch unless the engines are running but still in neutral (for safety's sake)! Prior to engaging the synchronizing switch, ensure that you are in a large body of water. Avoid a tight cove or narrow river, and docks, dams or other objects that may protrude into the body of water. Be certain that there is a minimum of other vessels or traffic as you will need room to perform this procedure.**



Engaging the engine synchronization functionality requires practice to master. Because the boat will be in gear and will move during the process, even after mastering the maneuver boat operators should synchronize engines only on bodies of water of sufficient size to accomplish the maneuver without making contact with other vessels or with inanimate objects, which could cause serious bodily injury or significant damage to the boat.

The port engine will have an RPM blip after the Synch switch is activated and the throttle is moved to wide-open throttle on the MariStar 280, X-80 and CSX 265. If the engine actually accelerates to wide-open throttle, then the Synch function did not take control of the port engine. In this instance, reduce the speed and return to Step 1.

The engines can be run at different levels of throttle BUT NOT WHEN UTILIZING THE SYNCH FUNCTION!

NOTE: DO NOT engage the Engine Synchronizing Switch when loading or unloading the boat from a trailer OR when docking. These maneuvers require a sensitive touch.

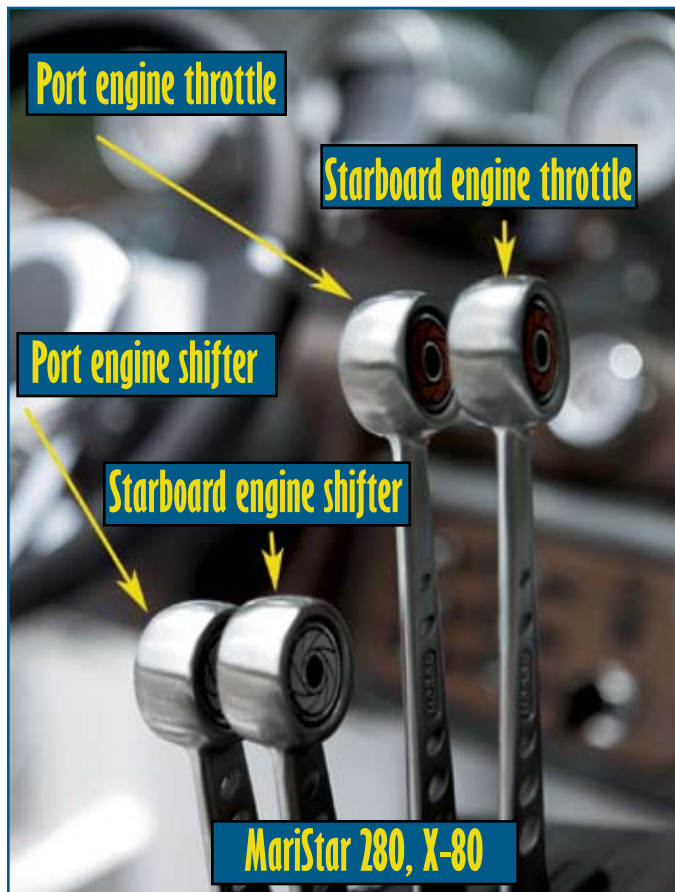

MariStar 280, X-80

Note: The MariStar 280 is equipped with a four-lever control. (See above image.)

- Step 1: Start both engines. While at idle and in neutral (shifter not moved), press up on the Synch switch to turn the synchronization function ON.
- Step 2: Push the **port throttle** to wide-open throttle. There will be a slight rise in RPMs to the engine (but the boat should not move forward as the shifting and throttle response are controlled with separate levers). With the Synch switch ON, however, the engine will very quickly return to idle.
- Step 3: Using the **starboard throttle**, run the boat up to the desired speed. At this point, the system will begin functioning with both engines in synch. The starboard throttle will control the speed for both engines as long as the synch switch is ON.

Note: Before disengaging the synch functionality, move ALL levers back to idle, beginning with the starboard throttle and shifter, and then the port throttle and shifter. When the boat returns to idle, the engine synchronizing switch can be turned off. Failure to follow this procedure may result in erratic handling of the boat, which may be beyond the boat operator's ability to handle.

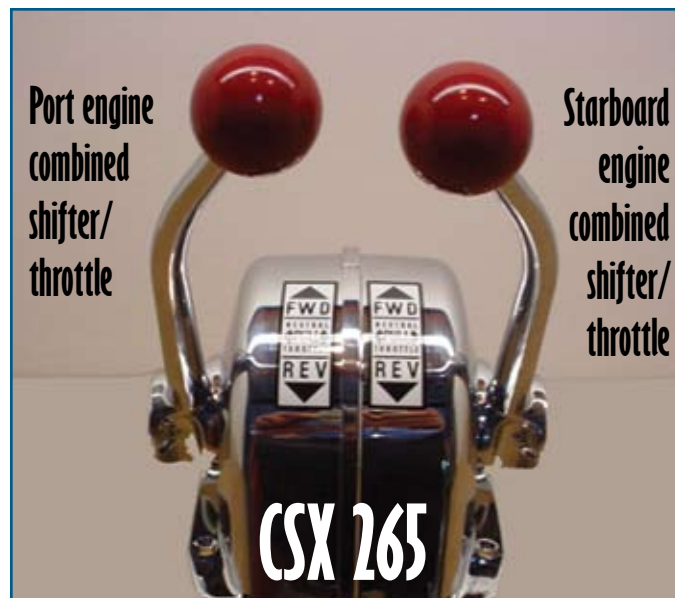

CSX 265

The CSX 265 is equipped with a two-lever control. (See above image.)

- Step 1: Start both engines. While at idle, press up on the Synch switch to turn the synchronization function ON.
- Step 2: Push the **port throttle** to wide-open throttle. There will be a slight rise in RPMs to the engine, which will cause the boat to move forward. **(This occurs because the shifting and throttle response are controlled with the same lever.)** With the Synch switch ON, however, the engine will very quickly return to idle, but the port engine remains in forward gear.
- Step 3: Using the **starboard throttle**, run the boat up to the desired speed. At this point, the system will begin functioning with both engines in synch. The starboard throttle will control the speed for both engines as long as the synch switch is ON.

Note: Before disengaging the synch functionality, move ALL levers back to idle, beginning with the starboard throttle and shifter, and then the port throttle and shifter. When the boat returns to idle, the engine synchronizing switch can be turned off. Failure to follow this procedure may result in erratic handling of the boat, which may be beyond the boat operator's ability to handle.



Fuel Gauge (All Models)

Fuel gauge readings are only approximate. This gauge is activated with the ignition switch. The rocking motion of the boat during normal operation will cause the fuel gauge to fluctuate. For a more accurate reading, make sure that the boat is level and there

is little or no motion present.

MasterCraft recommends that operators do not run the boat below a quarter of a tank, except as necessary to return to shore, and not until the boat has been operated enough times to develop an understanding of how the fuel gauge readings relate to the visual inspection of fuel left in the tank. Extending fuel usage beyond the known capability of the boat may cause the boat to run out of fuel and may leave you stranded off-shore.

Although it may be possible to see fuel in the bottom of the fuel

tank, you still may not be able to operate the boat. The fuel pick-up system was designed to avoid introducing the small amount of water and debris that unavoidably accumulate in the bottom of the tank. Rather than relying on visual inspection, you should pay attention to the fuel gauge.

Further, it is not recommended to allow the fuel to fall below one-quarter of a tank full at any time as it may result in damage to the fueling system. (See the *Fueling* section of this Owner's Manual.)

CAUTION

Allowing the fuel level in the fuel tank to fall below one-quarter of a tank full may affect the reliability of the fuel pump or result in damage to the fuel pump, which is not covered under warranty.



Heater Switch

(Optional Installation for All Models)

Among the accessory options available for your boat is a heater function. The heater's three-position switch is turned up for ON (LOW), or turned down for ON (HIGH). The

center position is OFF. Warmed air from an electrically powered heater box will be blown from vents within the boat deck.



Horn

(All Models)

The horn is sounded by means of a button on the instrument panel. Pressing the button emits a loud and recognizable noise.



Ignition Key Slot

(All Models)

MasterCraft boats come equipped with an ignition key, which must be inserted in the ignition key slot and used to activate the boat's electrical system. This, in turn, will allow the boat to be started and operated.

The key will be in one of four (4) positions:

- Off
 - Accessory (including running the stereo without the engine running)
 - ON (engine is running)
- Start (turn the key to engage the engine starter, then release to allow the key to automatically return to the ON position)

Never leave the ignition switch in the ON position without the engine running, as this will cause the battery to discharge.

Note: The *MariStar 280STS* is equipped with two (2) ignitions, one (1) for each engine, allowing the engines to operate independently of each other. Be sure to turn **both** ignitions OFF when the engine is not in use.



Instrument Panel Gauge

Backlighting Switch

(All models equipped with the Video Display Gauge System)

A three-position switch allows the operator to change the instrument panel backlighting for the gauges. Pressing the top of the switch will cause the lights to brighten, and pressing down will dim the lights.

Low Voltage Battery Alarm

(All Models)

In the event that the stereo has been functioning when the boat is not ON and running, the voltage drain on the battery (or batteries) may result in difficulties with re-starting the boat. It may also cause intermittent erroneous or fluctuating gauge readings. When the voltage level reaches 11.5 volts or below, the system will shut off the stereo and sound the alarm for a period of two (2) minutes to give boaters sufficient time to adjust. Generally, the appropriate action is to leave the stereo OFF, as well as disengaging any other peripheral electrical components, and keying ON the engine. Running the engine at a moderate rate for several minutes without the additional drain of stereo and unnecessary electrical equipment will allow the alternator to recharge the battery or batteries, unless the battery(ies) have been used to the extent of their life span.



Carbon monoxide is emitted from the engine's exhaust system. Never run the engine without proper ventilation. Do not run the engine in a confined space or where fumes may be trapped. Do not run the engine when the boat is stationary in calm wind conditions.



Multi-Function Gauge

(ProStar 190, ProStar 197, X-7, X-1, base MariStar models only)

This gauge provides several functions of interest and support to the boater. As a **tachometer**, it indicates the engine speed in crankshaft revolutions per minute (RPM).

As you toggle to the **hourmeter**, it registers the accumulated engine operating time. Use the hourmeter to keep accurate logs for scheduled maintenance. (See also the Maintenance Section and

Service Log.) Replacing the computer (known as the MMDC) will erase the registered hours. The hourmeter counts hours only when the engine is above 300 rpm.

The option exists to change the display to metric from the hours screen. This is done by holding down the gauge selection display button for three (3) seconds. When prompted, select English or metric display. Wait an additional three (3) seconds and the display will return to normal operation.

Toggle to the **air temperature gauge** (optional) to get an approximate reading of the ambient air temperature above the water's surface.

Toggle to the **clock** for the convenience of determining the time. It can be adjusted by depressing the gauge selection display button when the clock is displayed. After three (3) seconds the colon will stop

flashing. The hours are adjusted by pressing the button down, while minutes are adjusted by pressing up. After three (3) additional seconds the clock will return to normal operation.

Alarms of the Multi-Function Gauge

In addition to the displays noted above, the multi-function gauge also displays several alarms. The following messages will be displayed if an alarm occurs:

VOLT = Voltage falls below 11.5 volts. This message indicates that the battery has discharged to an extent that may jeopardize engine cranking and starting if action is not taken. Start the engine to at least idle, and allow the battery to re-charge.

OIL = Oil pressure is below 4 p.s.i. when the RPM is below 1000 RPM or the oil pressure is below 10 p.s.i. and above 1000 RPM. This message will occur only when the engine is running. Stop the engine and check the oil level as soon as this can be safely done.

TEMP = High engine temperature alarm. This message will occur only when the engine is running. If the engine does not automatically reduce speed to the “limp home” level, manually reduce speed and return to the dock as soon as this can be safely done. It may be necessary to shut down the engine and seek a tow to the dock.

TRAN = Transmission alarm. This message will occur only when the engine is running. Stop the engine and check the transmission oil level as soon as this can be safely done.

While air temperature readings are an optional addition to the gauge, the lake temperature reading is standard on the gauge. This comes from the paddle wheel located under the boat. If the sensor becomes open or shorts out in the line to the battery, it will read 32 degrees F. If the sensor is shorted to the ground wire, it will read 150 degrees F. The SELF-TEST feature of the multi-function gauge is located on the lake temperature gauge. With the lake temperature displayed, hold down the gauge selection display button for three (3) seconds or until the self test has started. During the self-test, all the segments on the display will light up. Also during the self test, the gauges will re-set, go to mid-scale and then to full-scale. After two (2) sweeps the system will return to normal.



Navigation/Anchor Lights Switch

(All Models)

A three-position switch serves to activate exterior lighting. Turning the switch in the up position will activate bow and stern lights, the middle position is OFF, and the down position is for stern-only lighting.

Other Alarms

(All Models)

Sensors check the oil pressure, engine and transmission temperatures. If the system detects readings outside the acceptable range, the system shuts off the stereo and sounds the alarm for a period of one (1) minute. This signals the need to return to shore as soon as possible and seek assistance from your authorized MasterCraft dealer's service department to diagnose and, if necessary, repair the problem.



Refrigerator Switch

(MariStar 280, X-80, CSX 265, X-65)

This switch will run the refrigerator when turned ON. The refrigerator runs off the boat's electrical

and battery system. Therefore, care should be given to ensure that the battery is not drained to such an extent that the voltmeter alarm sounds.



Seat Heat Switches

(Optional All Models for Driver's Seat; Certain Models for Observer's Seat)

A two-position switch allows heat to be turned ON for the driver's seat. In some models, an optional observer seat heat switch is available and will be found on the deck below the observer seat cushion. Note that this switch will operate only when the ignition is in the ON position.



Shift/Throttle Control

(All Models)

With the exception of the MariStar 280, X-80 and CSX-265, a one-hand, single-lever control operates as both a gear shifter and a throttle. The lever automatically locks in the neutral position (straight up and down) for safety. The lever can be moved from neutral only by raising the lifter under the ball knob. Shifting is accomplished by moving the lever forward or backward. Center (straight up) is neutral. Moving the lever forward engages the running gear; moving it back from center puts the drive train into reverse.

Never attempt to shift without the engine running!

During regular warm-up of the engine, it is possible to temporarily increase the engine RPMs without moving the boat. To accomplish this, push in the button located at the bottom of the shift/throttle lever with one hand and pull up the “umbrella” (aluminum surround below the top of the knob). Move the lever to desired position and then simultaneously release the button and umbrella. The engine will run with increased RPMs and can be increased or decreased by moving the lever. Returning the handle to the neutral position (as shown in illustration above) will bring the system back to neutral and reduce the engine RPMs to pre-set levels.

This function should be done sparingly. Over-revving the engine for any extended period can cause undue wear and tear on the engine. Avoid advancing to wide-open-throttle and holding the RPMs at that level.

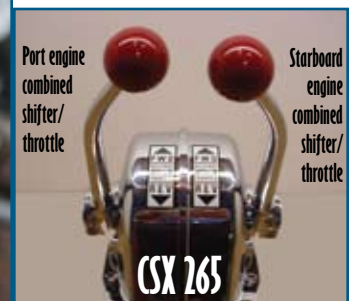
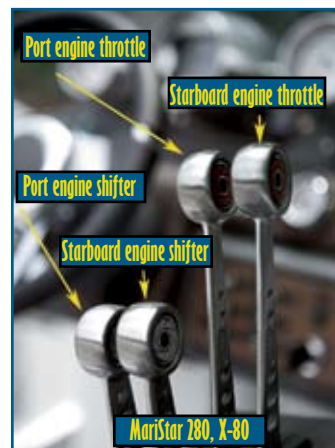

In the MariStar 280 and X-80 the boat is equipped with a four-lever control. The port side lever closest to the driver is the port engine shifter, which allows the boat to move forward when shifted forward, and backward when shifted aft. The next lever is the starboard engine shifter and performs the same function. If both engines are running and the boat is moving, the shifters should be shifted together and in the same direction. Doing otherwise can damage the system.

The next middle lever is the port engine throttle, which allows the boat to feed fuel into the engine and operate in motion. Pushing forward

on it will signal the system that fuel should be sent to the port engine. The engines can be run at different levels of throttle.

The CSX 265 has a two-lever control. On the port side is the port engine shifter/throttle control, and pushing forward will move the boat forward. The starboard side lever is the starboard engine shifter/throttle control. The engines can be run at different levels of throttle.

This system allows greater maneuverability in docking, as well as when the boat is in operation. **However, it requires more practice and skill in order to avoid potential damage to the boat. See Engine Synchronizing Switch in this section of the Owner's Manual for more details.**

During regular warm-up of the engine, it is possible to temporarily increase the engine RPMs without moving the boat. To accomplish this, pull outward (lateral to the unit) on the engine shift/throttle control. The engine will run with increased RPMs and can be increased or decreased by moving the lever. Returning the handle to the neutral position (as shown in illustration above) will bring the system back to neutral and reduce the engine RPMs to pre-set levels.

This function should be done sparingly. Over-revving the engine for any extended period can cause undue wear and tear on the engine. Avoid advancing to wide-open-throttle and holding the RPMs at that level.



Shower and/or Slick Boot Switch (Optional Installations on Most Models)

A single three-position switch mounted in an aft position storage area controls the optional shower and optional Slick Boot functions. The switch is marked for each. Turn the switch toward the Shower marking to

turn ON the shower. Return to center for OFF. Turn to the other direction to turn ON the Slick Boot. Return to center for OFF. These instructions work whether the boat is equipped with one (1) or both of the options, but will not be found in boats that are not equipped with either option.



Sink Switch (MariStar 280 and X-80)

On the face plate panel adjacent to the sink is a two-position switch. Turning the switch ON allows water to run through the faucet into the sink. The water comes from a freshwater tank that requires manual refilling when the water has run out. Be sure to turn

OFF the switch after running water, and especially when the freshwater tank has run dry.



Speedometer (All Models)

The speedometer indicates the forward speed of the boat in miles per hour (unless the boat is equipped with a speedometer that measures kilometers per hour, which is available in the optional European package.)

To calibrate the speedometer, you need an accurately measured course of 850 feet and a certified stopwatch, which is accurate to within one-hundredths (.01) of a second. (This can be done with GPS, when equipped.) To calibrate to A.W.S.A. official tournament rules:

- Approach the course at 36 miles per hour (MPH) as indicated on the speedometer. Hold the speed steady and have an observer check the course time with a stopwatch.
- If the course time is between 15.88 and 16.28 seconds, no adjustments are necessary.

- If the course time is not within that tolerance range, press up or down on the calibration rocker switch to adjust the speedometer's speed interpretation.



Tachometer (All Models)

On boats not equipped with a multi-function gauge, a separate tachometer gauge is found. The tachometer indicates the engine speed in crankshaft revolutions per minute (RPM).



Temperature Gauge (All Models)

The temperature gauge indicates the water temperature inside the engine's cooling system as measured in degrees Fahrenheit. The normal operating temperature will range from 140 degrees Fahrenheit to 190 degrees Fahrenheit. Engines with electronic fuel injection also have a control circuit inside the engine control module that will cause the engine to run at reduced speeds if the module senses that the engine is running too hot. If you notice that your speed has reduced during normal operation, but you have not manually slowed the throttle, monitor your temperature gauge. **If the gauge indicates excessive temperatures during operation, slow down immediately and turn off the engine.** This indicates an engine problem that needs to be checked by the dealer!

CAUTION

Continuing to operate the boat while the temperature is above normal operating parameters may cause serious damage to your engine. Damage to your engine resulting from operating the engine in an overheated condition can be costly to repair. Such damage is not covered by your warranty!



Tower Lights Switch (Optional Installation for All Models)

The location of the tower lights switch (where equipped) varies by model and should be located by the operator. In some instances, there may be two (2) switches. In all instances, the lights operate by using two-position switches, one position for ON and the other for OFF.



Underwater Lights Switch (All Models)

This switch is a two-position switch that activates the courtesy lights within the boat as well as the underwater lights (where equipped), simultaneously. Turning the switch upwards will turn the lights ON, and turning it downwards will turn the lights OFF.

Also note that the underwater lights should never be operated unless the boat is in the water. Even though these are L.E.D. lights, they generate some heat and require the cooling effect of the water to avoid premature burn-out of the bulb.



Video Display Gauge

(Standard on MariStar 230, MariStar 280, X-Star, X-2, X-14, X-15, X-30, X-45, and X-80; Optional on ProStar 214, MariStar 200, 215 and 245)

Many MasterCraft boats feature a color display gauge. The video display gauge is capable of displaying engine, boat, and Perfect Pass speed control information.

NOTE: At press time for this Owners Manual, additional functionality was being added to the Video Display

Gauge. All of the functions listed herein will be available. Additional items will be described by the brief manual provided by the manufacturer.

Information is divided into manageable pages or screens and organized into a straightforward menu structure for presentation to the driver. Display controls, conveniently located along the bottom of the gauge, allow rapid navigation of the menu structure to display any desired information.

Display navigation is intuitive. Pressing the **MENU** button brings up a display of the available information organized and illustrated as file tabs with each tab representing a screen of information. Repeatedly pressing the **MENU** button shuffles the tabs to bring a new tab to the top of the stack. Pressing the **SELECT** button initiates the screen represented by the tab on the top of the stack.

The system anticipates the need to display information and automatically brings up certain screens when they are necessary. For example, the system automatically displays a related screen when it senses any of the following events:

- Adjusting the trim brings up the Trim screen
- Adjusting the ballast brings up the Ballast screen
- Pushing the Perfect Pass button brings up the Perfect Pass screen
- Any alarm condition brings up a warning screen.

Selecting the **DEPTH** tab goes to the screen illustrated. This screen digitally displays depth, water temperature, air temperature, and illustrates the depth trend. The system also has a user adjustable depth alarm that can be adjusted from the **SET-UP** tab.

Selecting the **BALLAST** tab goes to the screen illustrated below. It allows the driver to see the status of all the ballast tanks installed in the boat. This tab is a plug and play tab so uninstalled ballast tanks do not appear on the screen.

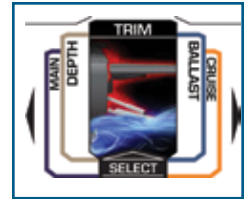
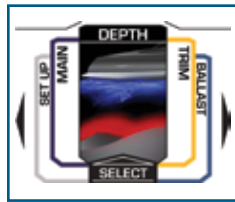
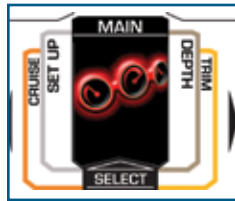

Selecting the **TRIM** tab goes to one of the screens illustrated below. These screens display the position of the installed single-trim tab or dual-trim tabs.

Selecting the **MAIN** tab goes to the screen illustrated in the next column. Any information available to the instrumentation system may be selected by the driver to be displayed in this screen. This screen is organized into four (4) quadrants with the user-selected information digitally displayed in each quadrant.

To change the information displayed simply:

- Press the **UP** or **DOWN** arrows to highlight the quadrant that you wish to change
- Press **SELECT** to access the pull-down menu
- Using the **UP** or **DOWN** arrows highlight the desired information.
- Press **SELECT** again to store the change

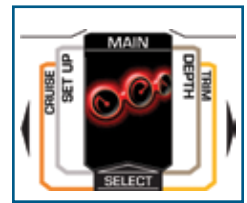

MasterCraft boats equipped with the video display gauge feature integrated Perfect Pass Wakeboard Pro speed control software.

The Perfect Pass application can be entered by selecting the **CRUISE** tab on the **MENU** screen or pressing the remote Perfect Pass button.

Perfect Pass is turned on and off by pressing the remote perfect pass button. Please refer to the Perfect Pass manual for detailed operating instructions.



All screens display a Perfect Pass icon when the Perfect Pass system is turned ON.

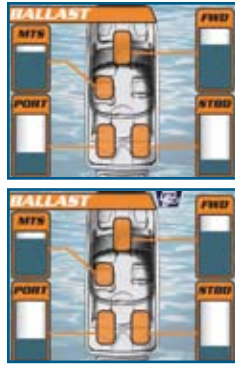

Selecting the **SET UP** tab goes to the pick list illustrated below. It contains all the system controls of the video display gauge. This tab permits control of alarms, speedometer calibration, brightness and contrast adjustment to name a few. Using the **UP** and **DOWN** arrows highlight the desired item and press **SELECT**. Make the desired changes and press **MENU** to save and exit.

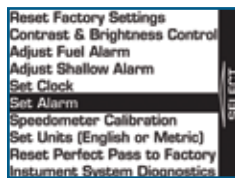
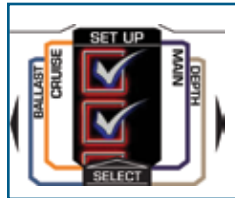

All system Warning Messages are displayed on the video display gauge. They will stay on for a minimum of 10 seconds but can be acknowledged and hidden by pressing the MENU button. Once acknowledged after 10 seconds the alarm will go away for 5 minutes. If the alarm is still active it will return after 5 minutes have elapsed.



Voltmeter (All Models)

The voltmeter registers the electrical activity necessary to operate your boat. If the battery (or batteries, in boat models requiring two [2]) is low or non-functional, or if various electrical items on the boat, such as stereo equipment, are draining the battery(ies) and impacting the

boat's ability to function properly, the voltmeter will likely be the first gauge to indicate that you have an electrical problem. The voltmeter cannot tell you which battery is draining on boats with two (2) batteries, but rather functions as a general alarm to alert boaters regarding potential issues. On boats equipped with two (2) batteries, the alarm indicates severe drain on the engine starting battery. To determine which battery is the engine starting battery, read the markings on the battery cables.



Wash Down Switch (Optional Installation for all MariStars CSX 220, CSX 265, and X-Star, including Saltwater Series)

A water tank option within available models can provide a fresh-water wash of the boat interior. The tank will be eight (8) or twenty-five (25) gallons capacity, depending on the boat model. The two-position switch is pressed up for ON and down for OFF.



Variations in Gauges and Switches

Please note that not every gauge or switch explained in this Owner's Manual is found on every model. Some equipment is optional and not every option is available on all models of MasterCraft boats.

Also, MasterCraft utilizes a variety of gauge and switch styles from the gauges or switches pictured in this Owners Manual. These differences between the various styles of gauges and switches are not in functionality. If a boat is equipped with a gauge or switch that is labeled as described above, it will operate in the same fashion as the description even if its appearance is different, as the appearance changes periodically.

If the owner and/or operators are uncertain about a gauge's or switch's purpose, do not operate the boat until consulting with an authorized MasterCraft dealer. Some gauges monitor information that is critical to safe and long-term use of the boat. Some switches can affect maneuverability, as well as operations that impact long-term use of the boat.

COMFORT AND CONVENIENCE

MasterCraft offers significant standard and optional items to make the boating experience more enjoyable. Some of these items come with their own instructions and information from the original manufacturer. In those instances, such as with the stereo equipment, the manual is included with the boat. In other instances, some general information is provided in this section.

If, at any time, you are uncertain about the use or care of anything on the boat, never hesitate to contact your authorized MasterCraft dealer for additional information and guidance.



Anchor and Windlass

Some models are equipped with anchors, and there will be a designated storage area or stowage location on the boat. Check with your dealer if you are uncertain about this area as it is important to keep the anchor stowed when it is not in use. In some models, the anchor is used in concert with a windlass, or winch, particularly in instances where the boat is expected to be used in deeper water. The windlass is a powered winch to raise the anchor and line.



Improperly stored anchors and/or anchor line that has been improperly re-wound through the windlass system, may create a hazardous situation. People on-board can trip on improperly stored materials, which can result in injury. Improperly stored materials can also move too freely during boat operation and make contact with individuals, again causing injury. Properly store all anchor and lines whether the boat is in operation or not, unless the anchor and line are in use.

To lower the anchor when accompanied by a windlass system, leave the engine(s) running to provide sufficient power. Raise the anchor door and remove any pins or lines securing the anchor in the bow roller. Remove the hand control from the under-side of the door. Stand clear of the anchor and chain. Press the ON button to enable the windlass. Press the DOWN button to lower the anchor.



The anchor, sometimes accompanied by a windlass, has been provided to assist boaters in remaining in a chosen location. Note that use of the anchor system

will not guarantee a properly anchored boat or that the boat will remain in a stationary position. Environmental, bottom conditions, current and tidal conditions must be taken into consideration when anchoring the boat. Only properly trained operators should set the anchor for this system. Establishing a secure anchorage requires practice. Damage to your boat may result due to improper anchoring techniques.

To raise the anchor when accompanied by a windlass system, start the engines to provide sufficient power. Raise the anchor locker door. Remove the hand control from the underside of the door. Stand clear of the anchor and chain. Press the ON button to enable the system, and press the UP button to raise the anchor. Properly stow the anchor and line.



Battery Charger

As a convenience, a battery charger is offered as an option. The charger is designed to recharge the batteries and also to extend the battery's life in applications where it is stored for long periods of time. These are three-stage electronic chargers, completely automatic, lightweight, and silent. Unlike most automotive chargers, this charger will not boil off the electrolytes in properly installed and maintained batteries. The red and green LED lights, which are mounted on the charger face, indicate when the unit is recharging and maintaining the batteries.

Before charging a battery, do not operate the charger if the cables or an LED is damaged. Be sure that all accessories are OFF. If the battery or batteries must be removed from the product, always remove the grounded terminal from the battery first. Be sure that the area around the battery is well ventilated while the battery is being charged. Also ensure that the battery terminals are free of corrosion. (See the *Scheduled Maintenance* section of this Owner's Manual for additional battery information.)

If the battery charger ever appears to be malfunctioning, see your authorized MasterCraft dealer for assistance.



When charging, batteries generate small amounts of dangerous hydrogen gas. This gas is highly explosive. Keep all sparks, flames and smoking well away from the area. Failure to follow instructions when charging a battery may cause an electrical charge or even an explosion of the battery, which could result in death or serious injury.



Canvas Covers

One of the most popular options for MasterCraft boats are the variety of canvas covers available. Speak with an authorized MasterCraft dealer for details about what is available for each model. MasterCraft strongly recommends having an authorized MasterCraft dealer perform the installation as snap installation can cause “crazing” (unwanted spider-web-like lines in the gel coat) if the installation is not done correctly.

On-going care of the canvas is required to keep the material in good condition for the life of the boat. See *Cleaning the Boat* section of this Owner’s Manual for more information.

Note that towing with unapproved covers on the boat may result in damage to the gel coat. MasterCraft recommends the use of our towable cover only for towing. Other canvas and covers have been developed and are available only through authorized MasterCraft dealers for a variety of uses.



Coolers

On many models, a removable cooler is included, particularly on models that do not have cold plates or a refrigerator. As with any similar Igloo-type cooler, routine cleaning with warm soapy water is advised after each use. Check also whether anything from inside the cooler has been spilled or in some manner ended up in the storage area in which the cooler is kept. This should be cleaned up immediately to avoid mold, mildew, stains or other damage that is not covered under warranty.

Food items or anything that can create an odor should not be left in the cooler. Neither should anything that can leak be left in these units as they could potentially damage the cooler, and this type of damage is not covered under warranty.



Fire Suppression and Extinguishing

The engine compartment of all V-drive and the CSX 265 models is equipped with an automatic fire suppression system with a manual override that uses a clean agent canister, which is housed in the engine compartment and is integrated with the fire suppression system. The direct drive and CSX 220 models are equipped with a fire port, into which the contents of a clean-agent canister can be released into the engine compartment.

Except as set forth below, you are also required by law to have on board one (1) five-pound, dry chemical fire extinguisher rated for Type A, B and C fires. The law requires that for all boats more than 26 feet in length, which includes the MariStar 280, X-80 and CSX 265 models, you must have on board two (2) five-pound, dry chemical fire extinguishers, rated for Class A, B and C fires. The dry chemical fire extinguisher is optional equipment, which is not automatically included in your boat from the factory, but it can be ordered from MasterCraft with your boat and can also be purchased from an authorized MasterCraft dealer.

If any of the fire suppression system canisters on board your boat are discharged (whether a canister in an automatic system or a portable fire extinguisher), then they must be replaced. The automatic fire suppression system available on all V-drive and CSX 265 models has an indicator light at the helm that will be green if the system is fully charged and will be red if the automatic fire suppression system has been discharged. If the clean agent canister associated with the automatic fire suppression system or the clean agent canister used in connection with a fire port has been discharged, then you must contact your authorized MasterCraft dealer to obtain a replacement for the clean agent type of canister. If the dry chemical fire extinguisher has been discharged, then may purchase a replacement five-pound dry chemical fire extinguisher that is rated for Type A, B and C fires from an authorized MasterCraft dealer or from another source.

Fire extinguishers require periodic maintenance. Monthly, each fire extinguisher on your boat should be examined to be sure that the seals and tamper indicators are not broken or missing. The pressure gauges or indicators, if applicable, should read in the operable range. There should be no obvious physical damage, rust, corrosion, leakage or clogged nozzles. Additionally, if the extinguisher has not been used, it should be weighed annually to assure that the minimum weight as stated on the label still exists. Any fire extinguisher that has been partially emptied must be replaced or taken to a qualified fire extinguisher servicing company for recharging.

Considerable additional information regarding the proper use of the fire suppression and extinguishing functions on MasterCraft boats is included in the *Boating Safety* section of this Owner’s Manual. Be certain to thoroughly review and understand that information prior to use of the boat the first time. MasterCraft recommends that boat owners include a check of the fire suppression and extinguisher units during the annual maintenance to be sure that they are always ready for use. Some units may not require annual checks; refer to the signage and labeling on the individual units for further guidance.



GPS and Chartplotter

All GPS and chartplotter systems come with extensive instruction manuals. Please refer to these manuals or the manufacturer's website for details and guidance.



Head

The following information is provided for the head installed in a MariStar 280 or X-80:

Preparing the head for use:

- Step 1: With the seat lid closed, pull the flush handle to open the slide valve. Then push to close. This relieves air pressure that may be created in the lower holding tank due to changes in temperature or altitude.
- Step 2: Remove the water cap and fill the upper tank until it reaches about 1 inch (25 mm) below the opening. Replace the cap.
- Step 3: Pull the flush handle to open slide valve.
- Step 4: Pour deodorant directly into the lower tank, then close the slide valve. Do NOT pour deodorant into the bowl with the slide valve closed.
- Step 5: Stroke the air pump about 15 times or until air emits through the relief valve on the water cap. Do not over-pressurize the upper tank by covering the relief valve. Do not let the upper tank pressurize when it is disconnected from the lower tank.

In using the toilet:

- Step 1: Before each use, with the seat lid closed, pull the flush han-

dle to open the slide valve, then push to close. This relieves air pressure that may be created in the lower holding tank due to changes in temperature or altitude.

- Step 2: Pull the flush handle to release waste in the lower tank.
- Step 3: Push the flush button to rinse the bowl. Push the flush handle to close the slide valve.

To empty the holding tank:

- Step 1: When the tank level indicator shows "FULL," or at the end of an outing, empty the lower tank.
- Step 2: Pull up on the rear latch to separate the upper tank from the lower tank. Carry the lower tank to an authorized waste disposal area or a normal toilet. **(DO NOT DISPOSE WASTE IN ANY LOCATION, INCLUDING NAVIGABLE BODIES OF WATER, WHERE SUCH DISPOSAL IS ILLEGAL OR CREATES AN ENVIRONMENTAL HAZARD.)**
- Step 3: Rotate the discharge spout away from the tank and open the vent on top of the holding tank. Empty the tank.
- Step 4: If water is available, rinse the lower tank before reassembling the portable toilet.



On the CSX 265 head, the following instructions should be followed:

Before operation:

- Step 1: Fill the freshwater tank and add deodorant to the holding tank through the toilet bowl.
- Step 2: Turn on the inlet water supply.
- Step 3: Turn on the electrical power to the system. (The breaker panel is located in the head compartment.)
- Step 4: Flush water into the system by depressing the flush lever (near the deck) until water starts flowing to the vacuum pump, which requires approximately 15 seconds. The vacuum pump will run for approximately 60-to-90 seconds. When the system reaches operation at the vacuum level, it will shut off.
- Step 5: Remember that the vacuum pump starts automatically. Shut off the system before servicing and do not leave the boat with the toilet system breaker on. (The breaker panel is located in the head compartment.) Never use drain openers, alcohol, solvents, etc., in the system as these are likely to damage the head.

Head operation:

- Step 1:** To add water to the head before using, raise the flush lever (near the deck) until the desired water level is reached. Generally, more water is needed only when flushing solids.
- Step 2:** To flush the head, press the flush lever sharply down to the deck until the contents clear the bowl. A sharp popping noise is normal when the vacuum seal is broken. Hold the lever down for three (3) seconds. After flushing, let the lever snap back into position. If the flush lever is accidentally released before waste clears the bowl, do not flush again until the vacuum pump stops running. A small amount of water remains in the bowl after flushing.
- Step 3:** Do not dispose of sanitary napkins or other non-dissolving items in the head. These items can cause plugging of the system.

Following operation:

- Step 1:** Dispose of waste properly. **(DO NOT DISPOSE OF WASTE IN ANY LOCATION, INCLUDING NAVIGABLE BODIES OF WATER, WHERE SUCH DISPOSAL IS ILLEGAL OR CREATES AN ENVIRONMENTAL HAZARD.)**
- Step 2:** Keep the system clean, using mild detergent or cleaner.

Both types of heads are supplied with in-depth instructions, which will be found in the head and should be removed and read prior to the first use of the system. Store the instructions with this Owner's Manual and other important material regarding the boat.

Use only rapid-dissolve toilet paper with these head systems, and only deodorant specially formulated for this type of head system. See instructions for details. In the event that anything from the head's bowl or holding tank escapes, it should be cleaned as soon as practicable. Failure to clean any spillage may result in unpleasant odors, mildew, mold and damage to the deck or other areas of the boat. This is not covered under warranty.

See the *Storage & Winterization* section of this Owner's Manual for important information regarding the preparation of the head for storage.



Heater

All MasterCraft models offer a heater option. The heater's three-position switch is turned up for ON (LOW), or turned down for ON (HIGH). The center position is OFF. Warmed air from an electrically powered heater box will be blown from vents within the boat deck. In regular use, the heater should not require any routine maintenance.

However, it is advisable to avoid placing items in front of the vents, particularly when the heater is in use. The heated air coming out could cause damage.

Never run the heater in a confined space, such as a garage or shop. Fumes from the engine can have deadly consequences. See also the *Common Sense Approach* section of this Owner's Manual regarding carbon monoxide danger.



Carbon monoxide is emitted from the engine's exhaust system. Never run the engine without proper ventilation. Do not run the engine in a confined space or where fumes may be trapped.



Hydraulic Steering System

Some models offer a hydraulic steering system as an option. At any time, if the steering is sluggish, difficult, or shows any signs of not working smoothly and properly, the boat should immediately be taken to an authorized MasterCraft dealer for attention. The hydraulic steering system is not accessible to the consumer for repair or maintenance, all of which should be done by an authorized MasterCraft dealer.



Lighting

Some models may be equipped with incandescent bulbs in the head, storage areas or in some instances in the forward and aft-facing lights. These lights are replaceable as would be any incandescent light bulb.

Other lighting that is L.E.D. will require replacement along with the housing in which they are contained. This includes the underwater lights, courtesy lights and other auxiliary lighting. These lights will need to be replaced by an authorized MasterCraft dealer.

Also note that the underwater lights should never be operated unless the boat is in the water. Even though these are L.E.D. lights, they generate some heat and require the cooling effect of the water to avoid premature burn-out of the bulb.



Livewell/Kill Box/Catch Box

One of the options on the CSX models is a fishing package. The boxes to hold catch are removable. Water is added manually to the boxes when desired. Be sure to remove the water and catch at the conclusion of the excursion. Leaving the water and/or catch can result in unpleasant odors, mildew, mold and other damage to the box that is not covered under warranty.



Refrigeration

Some models offer optional refrigeration. In the MariStar 280 and X-80 models, it is a refrigerator unit, which is free of CFCs, and instructions are provided by the manufacturer. In the CSX 265 models, cold plates are provided in the two storage bins under the seat that are immediately aft of the steering helm. These large stainless steel plates attach to the wall inside the storage bin, through which coolant circulates, similar to the operation of a regular refrigerator.

Note that the refrigerator and the cold plates function off the boat's electrical system. Attention should be paid to the Voltmeter(s) to be certain that these systems do not over-drain the electrical system.

On the MariStar 280 and X-80 refrigerator unit note that it can be used in an ambient air temperature range of -4 degrees Fahrenheit (-20 Celsius) to 130 F (55 C), and a maximum of 90 percent air humidity in constant operation. The device can cool goods in a temperature range of 28 degrees F (-2 C) to 53 degrees F (12 C). It is equipped with a battery monitor that switches the compressor off and on again, protecting the battery and the compressor against damage.

The refrigerator is suitable for cooling food. If you wish to cool medicine, please check to determine whether the cooling capacity is sufficient for the medicine in question.

Food items or anything that can create an odor should not be left in the refrigerator or cold plate areas. Neither should anything that can leak be left in these units as they could potentially damage the units, and this type of damage is not covered under warranty. The condenser on the refrigerator should be kept free of dust, dirt and anything that inhibits its proper operation. The manufacturer also recommends leaving the drawer slightly open if it will not be used for a period of time. This helps prevent unpleasant odors from forming.

Refrigerator cleaning instructions have been provided by the manufacturer. Note that it should always be OFF, and should never be cleaned under flowing water or submerged in any kind of body of water, including, but not limited to, a sink. Do not use abrasive cleaning agents. If it is necessary to defrost the interior, never remove layers of ice with hard or sharp tools as they can damage the plastic of the vaporizer. Allow the unit to air defrost.

The refrigerator operates by opening the coolbox door and turning the thermostat knob clockwise. Shutting it off requires turning the thermostat knob counterclockwise.

Seat Heaters

For real comfort, some models offer a seat heater option, which will be for the driver's seat, and sometimes in the observer's seat. It is not offered for any other seating in the boat. Note that the ignition must be ON for the seat heater to work. The heater(s) operate by a switch on the control panel. If the switch is turned ON and the seat does not warm up, or appears to become too warm, turn the switch to OFF and seek assistance from your authorized MasterCraft dealer in remedying the issue.

Shower or Wash Down

Many models offer a shower or wash down option. A single three-position switch mounted in an aft position storage area controls the optional shower and optional Slick Boot functions. The switch is marked for each. Turn the switch toward the Shower marking to turn ON the shower. Return to center for OFF. Turn to the other direction to turn ON the Slick Boot. Return to center for OFF. These instructions work whether the boat is equipped with one (1) or both of the options, but will not be found in boats that are not equipped with either option.

On MariStars, CSX 220 or 265, the X-Star and the Saltwater Series a tank option within available models can provide a fresh-water wash of the boat interior. The tank will be eight (8), ten (10) or twenty-five (25) gallons capacity, depending on the boat model. The two-position switch is pressed up for ON and down for OFF.

Do not use the shower with the engine running.



Carbon monoxide is emitted from the engine's exhaust system. Never run the engine without proper ventilation. Do not run the engine in a confined space or where fumes may be trapped.

Routine maintenance is not required beyond occasionally checking the lines and shower head to be certain these elements are not damaged in any fashion. Be certain to follow the *Storage & Winterization* section's instructions found elsewhere in this Owner's Manual.



Stereo Equipment

All stereo equipment, whether standard or optional equipment, comes with extensive instruction material. Please refer to this material or to the manufacturer's website for details and guidance.



Swim/Boarding Platforms

One of the most attractive aspects of all MasterCraft boats are the swim platforms attached to the transom of the boats. Whether teak or fiberglass with inlays, the swim platforms are a source of enjoyment.

MasterCraft reminds consumers to review the *Common Sense Approach* section of this Owner's Manual, and pay particular attention to avoiding "teak surfing" or "platform dragging," which expose the participant to excess carbon monoxide; and to the information regarding use of the optional shower while standing or sitting on the swim platform.



Carbon monoxide is a colorless, tasteless, odorless and poisonous gas that accumulates rapidly and can cause serious injury or death. Exposure to carbon monoxide can be fatal in a matter of minutes. Exposure to even low concentrations of carbon monoxide must not be ignored because the effects of exposure to carbon monoxide can build up and be just as lethal as high concentrations. Carbon monoxide from exhaust pipes of inboard or outboard engines may build up inside

and outside the boat in areas near exhaust vents, particularly during slow-speed operations. **STAY AWAY** from these exhaust vent areas, which are located at the stern of the boat, and **DO NOT** swim or engage in any watersports or other activities in or near the stern area of the boat, including, without limitation, the swim platform and the rear sun deck, when the engine is in operation. Under no circumstances should the owner and/or operator allow persons to hold onto the swim platform while the engine is operating and the boat is in motion. These activities (sometimes known as "teak surfing" or "platform dragging," where the participant holds onto the swim platform and is pulled through the water, and/or "body surfs" immediately behind the boat) are extremely dangerous, highly likely to result in death or serious bodily injury, and are a misuse of this product.

Some platforms feature a bracket, which allows the platform to fold down, reducing the amount of room required for storage. Note that the platforms themselves are fairly heavy, and releasing the bracket may result in the platform falling down and striking the transom with excessive force. Please provide support to the platform at the time of releasing the bracket, and slowly lower the platform into place for towing or storage.

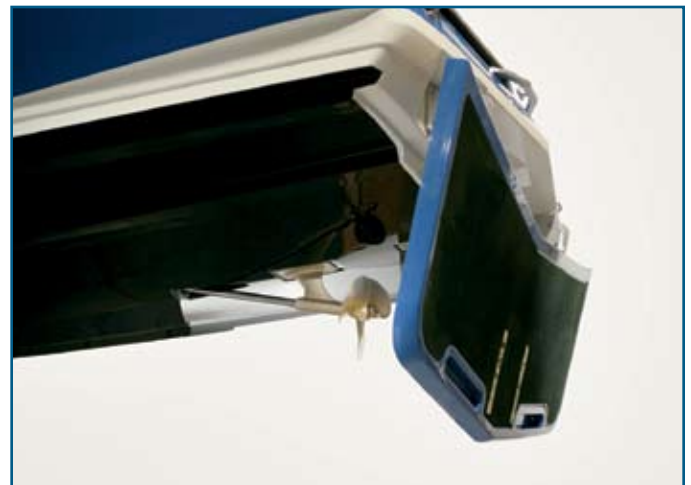

Many 2009 models are equipped with a swim platform that may be folded down. To determine whether the boat is so equipped, look beneath the platform and see if the bracket with pin appears as in the photo. If so, the swim platform can be folded. To do so properly, follow these instructions:



Folding Down the Platform

Remove the safety hinge pins in each swim platform bracket.

Begin by lifting the platform about four (4) inches upward while easing the platform away from the boat transom. This will allow the platform to move freely on the hinge.

NOTE: Ensure there is no tightness while the swim platform is being folded. There should be no binding during this action.



The platform must be raised and locked into position for transportation of the boat, as well as use of the platform while boating. Leaving the platform down may result in

damage to the boat transom during transport that will not be covered by the warranty!

Securing the Platform

- Step 1:** Lift the platform to approximately 20 degrees angle from the boat.
- Step 2:** Lightly push the platform (do not shove nor jam) toward the transom to allow the platform to set in place.
- Step 3:** Verify that the platform is in the locked position and will not fall down. Failure to verify that the platform is locked may result in the platform falling while someone is on it and could result in injury.
- Step 4:** Insert one (1) safety hinge pin into each platform bracket as shown in the top photo.



The platform must be raised and locked into position for use of the platform while boating. No one should be allowed on the platform until the platform is securely locked in place and the engine is OFF. Failure to do so may result in serious injury or death!



Tables

If the cockpit table option was selected for the applicable models, the table can be removed and stored. In doing so, ensure that the table and leg are secure in a storage compartment. If they are left out on the deck of the boat, they may shift or move and cause injury. Stored away, they should also be situated so that the metal top and bottom of the leg cannot rub against the table top and cause scratches. This type of damage will not be covered under warranty.

The bow table option on the CSX 265 does not remove for storage. Therefore, care should be taken to clean it regularly and avoid damage from spray or UV rays.

See the *Cleaning the Boat* section of this Owner's Manual for information on cleaning the surfaces of all tables.



Towers

Many MasterCraft models are now equipped with a tower, whether as part of a standard package or as an optional addition. Again, MasterCraft strongly encourages the occupants of the boat to review the *Common Sense Approach* and the *Boating Safety* sections of this Owner's Manual prior to use of the boat and the tower component.

Occupants of the boat should never stand, sit or jump from the tower. Nothing but MasterCraft-approved towing should be attempted. (See *Boating Safety* section of this Owner's Manual.)

Boat owners are strongly urged to purchase tower accessories only through an authorized MasterCraft dealer. MasterCraft has carefully determined the maximum amount of accessories and total weight that the tower can safely hold. Ignoring this information could result in injury to the boat operator and/or passengers.



MasterCraft has determined that for the tower utilized on the current models, the total weight of all accessories mounted on the tower should never exceed 85 pounds, regardless of whether the accessories are MasterCraft-approved and supplied or have come from an aftermarket supplier. Exceeding this restriction can result in tower failure, which could result in serious injury or death to the boat operator and/or passengers.



Video Screen

The CSX 265 offers a video screen that drops down from the T-Top option. See the accompanying instructional information to determine how to use the unit. (See *image above*.)



Water Heater

On the CSX 265 model, a four-gallon hot water heater is an option. Unlike the shower option on other models, which draws heat from a running engine, the CSX 265 water heater functions as a hot water retention tank after the engine has run.

The shower is located in the head compartment and at the transom. Water is drawn in by way of a pump that is turned on at the breaker panel in the head compartment. The heat is provided by running the port side engine for 15-to-20 minutes. After the water has been heated, however, the insulated tank will retain the hot water for several hours. This allows the shower to be run without the engine running, and if the engine is OFF, it is possible to shower while standing on the swim platform. (See *Common Sense Approach* section for cautions regarding using the shower with the engine running.)

The water pumped into the heater comes from a freshwater holding tank, and it can be left in the water heater when the boat is not in use, EXCEPT during extended periods of storage. As with any part of the boat in which there is water, it must be removed at the time the boat is winterized to avoid freezing that may cause damage to the boat, the holding tank or the water heater. The water is removed by running the shower until all the water has come out or by disconnecting the plumbing fittings in the forward service bay under the helm seats.



PREPARATION

USING CARE WHEN FUELING



MasterCraft boats are equipped with a highly innovative fuel system. This system is designed to provide years of trouble-free service. Some of the latest innovations related to fuel handling safety are also incorporated into the fuel delivery system.

The system uses a fuel pump mounted in a capsule that is installed directly in the fuel tank. A similar system has been used in automotive vehicles for many years and has demonstrated reliable service. The pump system in your boat was specifically designed for the marine environment and contains a number of added safety components that are unique to the marine environment. Because of the special nature of the design, there are no user-serviceable parts. Any parts in need of service or maintenance will need to be addressed by an authorized MasterCraft dealer. The authorized MasterCraft dealer there is equipped with the special tools necessary to disassemble and service the fuel capsule and associated parts. **Replacement parts must meet OEM requirements as specified by MasterCraft.**

The fuel line in the boat's bilge area that goes from the tank to the engine is a special multi-layer armored line that is covered with a special material known as a fire sleeve. The fire sleeve affords protection to the fuel line in the unlikely event of a boat fire.

The sleeve is colored orange for easy identification of the fuel line. MasterCraft recommends daily inspection of the bilge for foreign materials and the possibility of gas or oil leakage detection. As part of your daily inspection, include a visual check of the orange fire-sleeved fuel line. If you see damage to the sleeve or line or in any way suspect damage or fuel leakage, **DO NOT START THE BOAT!** Immediately call an authorized MasterCraft servicing dealer and let him or her assess the situation. Even if the outing is canceled, leaking fuel can cause serious damage to the environment and may be a potentially hazardous situation for people and property in the area. Therefore, it is critical to attend to any indication that there is fuel line damage or fuel leakage as soon as possible.

 **DANGER**

Gasoline is extremely flammable and highly explosive under certain conditions. Always stop the engine and never smoke or allow open flames or sparks within fifty (50) feet of the fueling area when fueling.

 **DANGER**

Take care not to spill gasoline. If gasoline is spilled accidentally, wipe up all traces of it with dry rags immediately and dispose of properly on shore.

 **DANGER**

Gasoline is explosive. If a gasoline odor is present or gasoline is visually observed in the bilge area during inspection, **DO NOT START YOUR ENGINE!** Remove the ignition key from the ignition switch and call an authorized MasterCraft dealer for service.

CAUTION

Allowing the fuel level in the fuel tank to fall below one-quarter of a tank full may affect the reliability of the fuel pump or result in damage to the fuel pump, which is not covered under warranty.

Indmar Engines

The following information applies to boats equipped with Indmar engines (which includes the RPT-1, MCX, LY6 and 8.1L):

What Type of Gasoline To Use

All standard Indmar EFI engines run on unleaded fuel of 89 octane or higher. Indmar recommends purchasing fuel from a supplier that advertises availability of fuel that meets "TOPTIER" specifications. This fuel has additives and detergents that will reduce the build-up of deposits in the engine.

The goal of the TOPTIER detergent gasoline standards is to create a winning situation for gasoline retailers, engine manufacturers and boat operators. Currently, many gasoline retailers provide fuels with lower-quality additive packages that can build up deposits on fuel injectors and intake valves. Others can build up deposits in combustion chambers and may lead to intake valves sticking. These lower levels of additives can have a negative impact on engine performance and vehicle responsiveness.

For a current list of gasoline retailers supplying TOPTIER gasoline, go to www.toptiergas.com and click on RETAILERS.

CAUTION

Damage to the engine by use of low-quality gasoline or gasoline with an octane rating below the minimum level listed will void the warranty on the boat.

CAUTION

Fuels that are blended to contain methanol or wood alcohol should not be used. These fuels can corrode metal parts in the fuel system and engine. Fuels that contain methanol will damage the engine. Damage caused by the use of unapproved fuels is not covered by warranty.

When the Boat Is Not Used for a While

Indmar recommends the regular use of Sta-Bil® fuel stabilizer for boat users whose outings consume less than a tank of fuel every two (2) weeks. Today's fuels are more susceptible to degradation, and the use of a quality stabilizer will help ensure fewer problems for the occasional boater.

If the boat has not been used for more than thirty (30) days and fuel remains in the tank (even stabilized fuel), the engine may run poorly until the "old" fuel is used up. The manufacturer will not pay for repairs to components that are inoperable or damaged from old and/or poor quality fuel, as this is not covered under the engine warranty.

CAUTION

Extended storage with fuel in the system can affect the fuel's stability and may require system inspection and fuel filter replacement when the unit is placed back into service.

Using Oxygenated Fuels or Fuels with Alcohol

MTBE (methyl tertiary butyl ether) is an oxygenate and octane enhancer. This compound may be blended with fuel. Fuel that is no more than fifteen percent (15%) MTBE is acceptable for use in the Indmar engine.

Ethyl alcohol, ethanol or grain alcohol is acceptable as long as it is a blend and the blended fuel contains no more than ten percent (10%) ethanol.

Fuels Outside the United States and Canada

If the Indmar-equipped boat is operated outside the USA or Canada, unleaded fuels may be difficult to obtain. Leaded fuels are not recommended as engine components will last longer using unleaded fuel.

Volkswagen Diesel Engine

If the MasterCraft boat is equipped with a Volkswagen diesel engine, refer to the owners manual that comes with it for important information regarding fueling and starting the engine.



SAFETY CHECKS AND SERVICES



The following checks and services are essential to safe boating and must be performed. Get in the habit of performing these checks in the same order each outing so that it becomes routine.



DO NOT launch or operate the boat if any problem is found during the Safety Check. A problem could lead to an accident during the outing, resulting in death or serious injury. Any and all problems should receive attention immediately. See your authorized MasterCraft dealer's service department for assistance.

Before Each Operation

These tasks are best accomplished before the boat is launched.

- Follow all engine and drive train pre-operation maintenance and safety checks as outlined in the engine owner's manual provided.
- Check the weather report, wind and water conditions.
- Check for recommended on-board tools and parts.
- Check that all drain plugs are installed properly, including bilge and rear drain.
- Check the propeller and shaft for damage.
- Check that there is an adequate supply of fuel.
- Check that the steering system operates properly.
- Check that required safety equipment is on board.
- Check that the windshield and extrusions do not show any damage.

CAUTION

When boating, avoid using the windshield as an aid for balance or getting out of a seat. This causes undue stress to the window frame and could damage it, which may not be covered under warranty.

- Check that the fire extinguisher is fully charged.
- Check that no fuel, oil or water is leaking or has leaked into the bilge compartment.
- Check all hoses and connections for leakage or damage.
- Check that all required **Scheduled Maintenance Checks and Services** (see following sections) were performed.

During Operation

- Check gauges frequently for operating conditions.
- Pay attention that controls operate smoothly.
- Note any excessive vibration.

After Operation

- Check for fluid leaks.
- In boats equipped with a ballast system, drain water from the ballast system before placing the boat on the trailer. If the boat has ballast-pumping assistance to remove water from the ballast system, note that the engine must be running at least 1500 RPM during the pumping process (for both fill and empty operations). This will necessitate draining water prior to ceasing operation of the boat and loading on the trailer. More information regarding ballast systems appears in various sections of this Owner's Manual.
- Check the fins (where equipped), propeller, rudder and shaft for damage after removing the boat from the water.



NEW BOAT BREAK-IN



The first fifty (50) hours of operation are the most important for the boat. Proper break-in will ensure maximum performance and the longest possible power-train life. The break-in period allows moving parts within the engine and transmission to wear-in properly. All MasterCraft boats are lake-tested on the water before leaving the factory, but the break-in must continue for the first fifty (50) hours of your ownership.

CAUTION

To ensure proper break-in and lubrication, boat owners should not remove the factory break-in oil until after the initial ten (10) hours of operation. At that time, an oil change should be performed on the Indmar engines by an authorized MasterCraft service technician at an authorized MasterCraft dealer.

Failure to follow the break-in procedure exactly as stated will void the engine warranty!

NOTE: Before operating the boat for the first time you must read the engine manufacturer's manual completely in addition to this Manual!

Please follow the break-in procedure carefully. Close attention to the following is very important:

- **Maintain the proper oil level.** Until the piston rings, cylinder and other working internal parts are thoroughly seated, oil consumption can be high and must be carefully watched. (This continues to be important after break-in, as well).
- **Pay close attention to the gauges.** It is important to stop the engine immediately if the gauges indicate a problem. Low oil pressure and overheating are serious issues and require immediate attention.
- **Abnormal vibration or noises.** These symptoms can precede trouble and should not be ignored. Occasionally, hardware may work loose, mountings may need to be tightened or the driveline may require attention.

- **Fuel, oil or water leaks.** Leaks can pose a serious safety threat. If one occurs, it is most likely to do so after a few hours of operation.
- **Vary the engine speed.** Never run the engine for more than three (3) minutes at any constant RPM during the break-in period. Doing this will assist in the proper break-in of rings and bearings.
- **Plane the boat quickly.** Operating the boat at low speeds places an excessive load on the engine. Plane quickly, then back down to a slower speed.

First Hours of Operation

Each engine manufacturer has detailed and specific requirements for proper engine break-in. That information is found in the engine manual supplied, and must be followed exactly as indicated. Failure to do so could cause engine damage and/or failure that is not covered under warranty.

After Break-In

Once the break-in period is over, the boat may be operated continuously at any speed, but not beyond the maximum indicated in the engine manual.

The engines are equipped with rev-limiters which will cause a fluttering sound when reached. If the boat has the correct propeller set-up, operators should never reach the limiter, but if that happens, it is a signal that you should reduce the throttle and check with an authorized MasterCraft dealer to determine the cause.

Always remember that during normal operation you should allow the engine to warm up gradually. Be sure the engine is warm before accelerating. Pay careful attention to the gauges. Also, check the oil level frequently during the first fifty (50) hours of operation since the piston rings and cylinders require that much time to seat properly.

See the *Scheduled Maintenance Checks and Services* section for more details.

CAUTION

Failure to follow the engine oil recommendations listed in the engine manual can cause additional engine wear and increase the possibility of engine component failure. Damage to the engine due to incorrect oil usage can be costly to repair, and is not covered by the warranty!

STARTING AND BASIC OPERATION



NOTE: If you are operating this boat for the first time, you must follow the engine and drive train break-in procedures as described in the previous section and the engine manual. Failure to follow these procedures may result in serious damage and may void any warranties!

Before Starting

Familiarize yourself with the controls and indicators used on this MasterCraft boat. Perform all Safety Checks and Services as described earlier. Also perform all Scheduled Maintenance Checks and Services.

- Step 1: Lift the engine cover and inspect the bilge and engine compartment for any fluid/vapor leakage. MasterCraft recommends lifting the engine compartment cover for inspection before each use.
- Step 2: Check the hull drain plugs. Make sure they are installed and secure.
- Step 3: Operate the bilge blower for at least four (4) minutes. Leave the bilge blower ON through the starting process and until the boat has planed.



To prevent a possible explosion, operate the blower for at least four (4) minutes before starting the engine and always when at idle or slow-running speed. Explosive gasoline and/or battery fumes may be present in the engine compartment. Failure to do so may result in serious injury or death!



Before starting the engine, open the engine compartment and check for gasoline fumes, fuel and oil leaks or the presence of fuel or oil in the bilge.

NOTE: Always start the engine with the control lever in the neutral position or with the shift disengaged. Your boat is equipped with a neutral-start safety switch that will not allow the engine to be started when in gear.

Starting the Engine

- Step 1: Attach the emergency engine safety switch tether (lanyard) to an article of your clothing and to the switch.
- Step 2: For normal starting, leave the throttle lever in neutral. The electronic controls will meter the correct fuel and air automatically.
- Step 3: Turn the key switch to the start position and hold until the engine starts. Release the key as soon as the engine starts.

CAUTION

Do not operate the starter motor continuously for more than fifteen (15) seconds without at least two (2) minutes for a “cool-down” period. Failure to do so may cause the starter to overheat, resulting in damage. Failure to release the ignition key after the engine has started may cause damage to the starter motor and drive.

Note: While the engine is warming up, check to see that all lights and gauges operate properly. Check that the steering system operates freely. There should be no apparent leaks under pressure. Re-engage the control lever after warm-up by returning the lever to neutral and pushing the throttle button back into the engage position.

Shifting Gears

When shifting gears, always move the control lever smoothly and quickly into gear. Do not hesitate. Slow gear engagement could damage the shifting mechanism in the transmission.

NOTE: When shifting from forward to reverse or reverse to forward, be sure to stop the control lever in the neutral position and allow the engine to fall between 600-800 RPM before completing the shift.

With the exception of the MariStar 280, X-80 and CSX-265, a one-hand, single-lever control operates as both a gear shifter and a throttle. The lever automatically locks in the neutral position (straight up and down) for safety. The lever can be moved from neutral only by raising the lifter under the ball knob. Shifting is accomplished by moving the lever forward or backward. Center (straight up) is neutral. Moving the lever forward engages the running gear; moving it back from center puts the drive train into reverse.

Never attempt to shift without the engine running!

During regular warm-up of the engine, it is possible to temporarily increase the engine RPMs without moving the boat. To accomplish this, push in the button located at the bottom of the shift/throttle lever with one hand and pull up the “umbrella” (aluminum surround below the top of the knob). Move the lever to desired position and then simultaneously release the button and umbrella. The engine will run with increased RPMs and can be increased or decreased by moving the lever. Returning the handle to the neutral position (as shown

in illustration above) will bring the system back to neutral and reduce the engine RPMs to pre-set levels.

This function should be done sparingly. Over-revving the engine for any extended period can cause undue wear and tear on the engine. Avoid advancing to wide-open-throttle and holding the RPMs at that level.

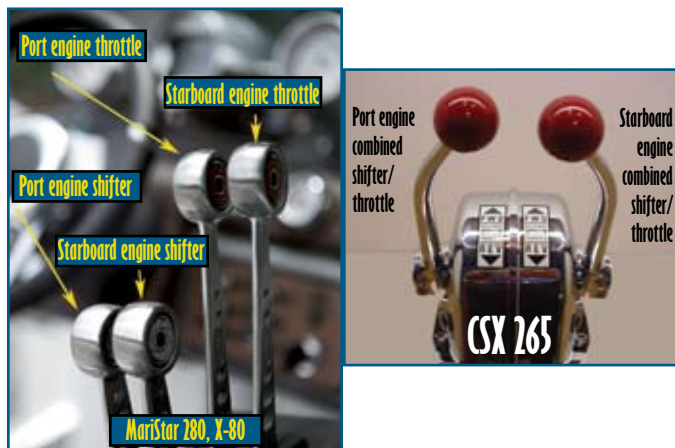

In the MariStar 280 and X-80 the boat is equipped with a four-lever control. The port side lever closest to the driver is the port engine shifter, which allows the boat to move forward when shifted forward, and backward when shifted aft. The next lever is the starboard engine shifter and performs the same function. If both engines are running and the boat is moving, the shifters should be shifted together and in the same direction. Doing otherwise can damage the system.

The next middle lever is the port engine throttle, which allows the boat to feed fuel into the engine and operate in motion. Pushing forward on it will signal the system that fuel should be sent to the port engine. The engines can be run at different levels of throttle.

The CSX 265 has a two-lever control. On the port side is the port engine shifter/throttle control, and pushing forward will move the boat forward. The starboard side lever is the starboard engine shifter/throttle control. The engines can be run at different levels of throttle.

This system allows greater maneuverability in docking, as well as when the boat is in operation. **However, it requires more practice and skill in order to avoid potential damage to the boat. See Engine Synchronizing Switch in this section of the Owner's Manual for more details.**

During regular warm-up of the engine, it is possible to temporarily increase the engine RPMs without moving the boat. To accomplish this, pull outward (lateral to the unit) on the engine shift/throttle control. The engine will run with increased RPMs and can be increased or decreased by moving the lever. Returning the handle to the neutral position (as shown in illustration above) will bring the system back to neutral and reduce the engine RPMs to pre-set levels.

This function should be done sparingly. Over-revving the engine for any extended period can cause undue wear and tear on the engine. Avoid advancing to wide-open-throttle and holding the RPMs at that level.

Underway

If the oil pressure gauge indicates low or no oil pressure, immediately stop the boat as outlined below and check the oil level. If the temperature gauge indicates overheating, immediately stop the boat as outlined below and check the raw water impeller for blockage. **DO NOT** operate the boat until the cause for the warning has been found and corrected.

CAUTION

Continued operation after the warning light has illuminated may cause severe engine damage. This will void your warranty.

Stopping

- Step 1: Slowly bring the control lever to the neutral position. If the boat has been driven for a long period of time or at high speed, allow the engine a 2-3 minute cool-down period at low idle (600-800 RPM).
- Step 2: Turn the ignition key to the OFF position to stop the engine.
- Step 3: If any problems were encountered during operation, have the boat inspected by an authorized MasterCraft dealer. Request any necessary repairs before resuming operation of the boat.



OPERATIONAL HINTS



MasterCraft urges all who will be operating the boat to seek certified instruction from the local boating authorities. This section is designed to present the most basic operational principles. It is NOT intended to cover all conditions encountered during operation. Therefore, the principles presented in this Owner's Manual are limited to the facts related directly to the operation of the boat, while the responsibility for the proper application of these principles belongs with the boat owner and/or operator.



Adding additional ballast to a MasterCraft boat is not recommended, and can result in impaired visibility, diminished handling characteristics and instability when operating your boat, and may result in potential structural and/or engine damage to the boat, which damage will not be covered by your warranty.

Loading

Never overload the boat. The maximum weight capacity as listed on the certification plate includes all items added to the boat (including persons and gear). Proper distribution of weight is critical to boat performance. Allocate the load as evenly as possible. The maximum weight capacity includes filled, factory-installed ballast tanks and/or ballast bags, added by the customer.

Note that adding ballast bags reduces the number of people and the amount of gear that can be added. Failure to adhere to the total maximum capacity may result in too much strain on the drive train or may sink the boat. This is not covered under warranty! See the Common Sense Approach section of this Owner's Manual regarding weight, including calculations for ballast and gasoline.



Information regarding the maximum number of people and/or additional weight to the boat is included in the Guide to Individual Models section of this Manual. It is the boat operator's responsibility to ensure that the boat is never overloaded. Too much additional weight may cause the boat to overturn or sink, which can result in serious bodily injury or death.

Emergencies

Know how to use and spot distress signals, and to offer assistance if possible. Remember, you may need assistance some day.

Courtesy

Always respect the rights of others on the water. Keep wide when passing, slow down in crowded areas, be alert and be aware of your wake and wash.

First Time Operation

When taking to the water for the first time, you must keep in mind a few general guidelines:

- **Practice makes perfect!** Start in calm water with no wind or current and plenty of room until you get the feel for the boat and its controls.
- **Proceed slowly!** Give yourself time to think, react and maneuver.
- **Recognize outside forces!** Check the wind direction and velocity, as well as water currents and waves.
- **Have a crew on hand!** Have friends or family ready with fenders, lines and a boat hook to assist you when docking, as well as launching and loading.
- **Remember that a boat is not an automobile!** Boats cannot be maneuvered and stopped like a car. Boats steer from the stern (rear) and have no brakes.

Basic Maneuvering

Steering response is dependent upon three (3) factors: rudder position, motion and throttle. While high-speed maneuvering is relatively easy and takes little practice, slow-speed maneuvering is far more difficult and requires time and practice to master. With both steering and propulsion at the rear of the boat, the initiation of a turn pushes the stern of the boat away from the direction of the turn. The stern follows a larger turning circle than the bow. This is especially important to remember when making maneuvers within close quarters.

While the effects of unequal propeller thrust (torque steering), wind, and current may not always be present, a practiced driver will use them to his/her advantage.

Unequal thrust is a phenomenon shared by all single-engine, propeller-driven boats. With the rudder in the straight-ahead position, a counterclockwise rotation propeller tends to cause the boat to drive to port when going forward, and to starboard when going backward.

At high speed, there is compensation for this effect, and it is virtually non-existent. But, at slow speed—and especially during backing—the effect can be very pronounced. This is the main reason that most experienced drivers approach with the dock to the starboard of the boat.

Stopping—or checking headway—is a technique that must be mastered. With no brakes, reverse must be used to stop the boat. The momentum of the boat will vary according to the load. Make it a practice to slow to no-wake speed before shifting into reverse.

When practicing maneuvering techniques, always do so in open water that is free of traffic. Adequate practice may make the difference between a pleasurable boating experience or a potentially damaging (at the very least, embarrassing) one.

High Speed Operation

MasterCraft boats are designed to be a high-performance boat. Professional drivers with advanced operating skills perform high-speed maneuvers and turns on-a-dime. DO NOT attempt to duplicate or simulate these feats. Paid, professional drivers log thousands of hours on the water and carefully choreograph every move. Plans are made in advance in the event the routine must be aborted. Maneuvers of this nature could cause serious injury or death, as well as damage to your MasterCraft boat that will not be covered under warranty.



Boat operators should never attempt to duplicate operational skills of professional drivers. When such maneuvers fail, it can result in serious injury or death.

For the best engine performance and longevity, the wide-open-throttle (WOT) engine operation must be near the top of, but within, the specified WOT operating range. To adjust the WOT operating range, select a propeller with the proper diameter and pitch. The propeller supplied on the boat was chosen for best all-around performance under average operating conditions.

Load, weather, altitude and boat condition all affect WOT engine operation. If the boat is used for several different applications such as wakeboarding, barefooting and cruising, it may be necessary to have two (2) or more propellers of differing size and pitch to allow the engine to operate in the WOT range for each application.

Propping the boat should be done after the boat is loaded in the manner in which it would normally be loaded for each application. For example, in propping the boat for wakeboarding, fill the ballast tanks and add the people and gear that normally would be expected in the boat. Take the boat out and after warm-up, run it at wide-open-throttle and note the maximum RPM. EFI engines are equipped with RPM limiters to prevent over-revving. Take note if the RPM limiter is activated.

If the WOT RPM is higher than the maximum RPM in your engine's WOT operating range, the boat is under-propped. Installing a higher-pitched propeller will reduce the WOT RPMs. An engine that is over-revving may quickly experience catastrophic damage, which will not be covered under warranty.

If the WOT RPM is lower than the minimum RPM in your engine's WOT operating range, the boat is over-propped. Installing a lower-pitched propeller will increase WOT RPMs.

An engine that is under-revving is "lugging." This places a tremendous load on the pistons, crankshaft and bearings and can cause detonation, piston seizure and other engine damage, which will not be covered under warranty.

CAUTION

Engines should always be operated within engine manufacturer guidelines. Failure to do so may cause significant damage to the engine and drive train and is not covered under warranty!

Elevation and weather also have a very noticeable effect on the wide-open-throttle power of an engine. Since oxygen gets thinner as elevation increases, the engine begins to starve for air. Humidity, barometric pressure and temperature have a noticeable effect on the density of air since heat and humidity thin the air.

This phenomenon can become particularly apparent when an engine is propped for use on a cool, dry day in spring and then is operated on a hot, humid day in summer, and does not have the same performance. Although some performance can be regained by dropping to a lower-pitch propeller, the basic condition still exists. The propeller is too large in diameter for the reduced power output. An experienced marine dealer can determine how much diameter to remove from a lower-pitch propeller for specific high-elevation locations.

MasterCraft's engine manufacturers suggest that consumers consult with the dealer from whom the boat was purchased regarding the best propeller for the application in which the boat will primarily be run. However, be aware that changing the propeller may void the warranty. Again, working with an authorized MasterCraft dealer is your best bet to ensure excellent performance.

Unusual Operating Conditions

If the body of water is unknown, talk to local boaters about the type of obstacles that may be encountered beneath the water's surface. Rocks, tree stumps and sandbars are all dangerous and damaging. Be especially wary of rivers and man-made lakes. Rapidly changing conditions can cause daily changes in underwater hazards.

Stay well clear of floating debris. What looks to be a small branch in the water may well turn out to be an entire tree.

When traveling through weedy areas, keep an eye on the engine temperature gauge. Weeds caught up and blocking the water flow through the raw water intake or transmission cooler will cause trouble. Also, after leaving the weedy area, shift to neutral for a few seconds and then to reverse for a few seconds to unwind any weeds that may have wrapped around the propeller.





Docking and Tie-Up

Approach the dock slowly, with the starboard side of the boat if possible. The natural tendency to torque steer with the rotation of the propeller at slow speeds makes docking easier on that side. Also, use wind and current to your advantage when docking.

Before tying up the boat, be sure to use enough dock bumpers to protect the boat from damage. If possible, tie-up with the bow toward the waves. Use good quality double-braided nylon line. Tie-up only to the lifting or tie-down eyes. Never use the handrails or ski pylon.

If the boat is to be moored for a long period of time, use chafing protectors to protect the gel coat finish. Leave a little slack in the lines, allowing for some wave movement or tidal action where applicable.

If the boat is to be kept in or near water for the season, consider the purchase of a boat lift and bottom paint for the hull. These lifts prevent the build-up of marine growth on the hull as well as protecting the boat from damage typical of on-water storage, such as blistering. Make sure the boat lift supports the hull correctly. See the next section, *Lifting the Boat*.

NOTE: On boats that are equipped with the engine synchronizing switch (models with two engines), this switch should be disengaged during docking or when loading and unloading the boat from a trailer. These maneuvers require a sensitive touch and control that may not be realized when the switch is engaged.

CARE AND MAINTENANCE



LIFTING THE BOAT



When the boat is hoisted from the water, proper use of the stern eyes or a sling system is required for all MasterCraft models. Though stern eyes are designed to lift a boat from the water, care must be taken to ensure you do not damage your boat. A spreader bar used at the stern, will help ensure that the load at the stern eyes is vertical. A strap placed between stern eyes, and then lifted from the mid-point, is not the recommended method, and will put substantial additional stress on the stern eye mounting location.

CAUTION

DO NOT use the ski pylon or any portion of any tower for lifting. They are NOT designed to be used as a central lifting point. Also, DO NOT use the stern ski tow as a lifting ring. The deck may be damaged. See the Storage Cradle sub-section of this section. Also never lift a boat with water in the bilge or containing a water-filled device such as a ballast system or sack. The extra stress will put an excessive load on the hull and lifting equipment that may seriously damage the boat. Such damage may not be covered by the warranty.

Using Lifting Eyes

An overhead hoist with a minimum two-ton capacity should be used to lift your boat. Cables should be properly rated for each model. Each cable should be rated at or above the full weight of the model to be lifted. *When lifting, keep the bow slightly higher than the stern to prevent any possibility of water running into the engine exhaust manifold.*

Using Lifting Slings

An overhead hoist with a minimum two-ton capacity should be used. Slings must be six (6) inches wide by twenty (20) feet long and each sling should have a minimum capacity rating that is equivalent to the weight of the model that is to be lifted. Use an eight-foot spreader bar on each sling to prevent damaging side pressure to the deck or gunwale molding.

CAUTION

Lifting slings must never contact shafts, struts or hardware protruding from the hull. Damage may result that would void the warranty.

CAUTION

When the boat is out of the water, it is important to support the hull correctly to avoid any hull damage. Such damage may void the warranty.

Storage Cradle

If a storage cradle is used, the hull must be properly supported to prevent load damage. This can occur with as little as fifteen (15) pounds per square inch of pressure. **DO NOT** support the boat by resting the hull on the keel (the central fore-and-aft structural member in the bottom of the boat's hull, extending from the bow to the stern). Vertical supports must extend from the chine (the angular intersection of the bottom and sides of the boat) to the keel with no gaps between the hull and cradle supports. A total support area of at least 250 square inches is required for proper support of boats under 25' and 500 square inches for boats over 25'. Protect all items extending from the hull (i.e., the rudder, propeller, fins, etc.) to prevent them from resting on the cradle or the ground. **DO NOT** apply any load stress to the propeller, shaft, rudder, swim platform, water intake grate or other protruding items.

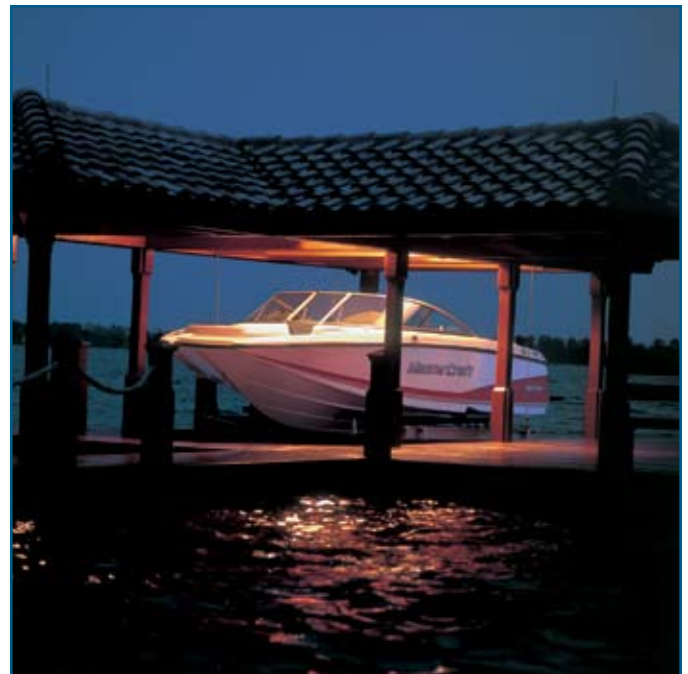

CORROSION PREVENTION



NOTE: DAMAGE DUE TO CORROSION IS NOT COVERED UNDER WARRANTY!

Galvanic Corrosion

Galvanic corrosion (electrolysis) to the boat is the decomposition of metal due to the effects of electrolytic action. When two (2) dissimilar metals are immersed in a conductive fluid (e.g., salt water), an electric current is produced, much like the action of a battery. As the current flows, it takes with it tiny bits of the softer metal. If left unchecked, severe damage may occur over time.

If the boat is operated in salt, polluted or brackish waters, even temporarily, the boat should be equipped with a transom-mounted zinc anode to prevent damage to those metal parts coming in contact with the water.

The zinc is, by design, self-sacrificing. It is slowly eroded away by electrolytic action and requires periodic inspection for deterioration.

If the zinc shows extreme erosion, it must be replaced to continue protection, or damage to other metal parts may result.

MasterCraft Saltwater Series boats come equipped with the zinc anode. For fresh water boats that may be operated in polluted or brackish water, an authorized MasterCraft dealer can provide guidance in securing and installing a zinc anode for protection.

Salt Water Corrosion

The boat has been designed for operation in fresh water unless it is a model in the MasterCraft Saltwater Series. If operating a fresh-water model temporarily in salt, polluted or brackish water, thoroughly flush the boat with fresh water as soon as possible afterward. The entire engine cooling system should be flushed with fresh water for at least ten (10) minutes after each use in such waters.

Boats operated continuously in salt water should be equipped with the closed cooling system to preserve engine life.

Marine Growth

If accelerated marine growth is a problem in the area in which the boat will generally be operated, an anti-fouling bottom paint may be necessary to slow growth while protecting the gel coat.

Before selecting a bottom paint, talk with other boaters and an authorized MasterCraft dealer's service department to determine the product that works best in the area. Many local variables may also affect the selection of paint. Be sure to follow the paint manufacturer's directions exactly.

CAUTION

Be sure all fasteners used are approved and rated for marine use. Most fasteners used on MasterCraft boats are stainless steel or specially coated to resist corrosion.

WARNING

Use of improper parts may cause component or engine failure. Such failure may result in death or serious injury!

Stainless Steel and Chrome

Stainless steel and chrome-plated parts are not totally resistant to corrosion. Occasional cleaning and polishing with a marine chrome-and-stainless polish will maintain and extend the life of these parts. In salt water areas, it is imperative that you thoroughly rinse all hardware with fresh water and apply a light coating of protective oil to enhance the appearance after each use.

CAUTION

Exposure to salt water will cause corrosion leading to significant damage to stainless steel and chrome parts. Failure to thoroughly rinse salt water from all hardware, and to apply protective oil after each exposure to salt water, will accelerate the corrosion of hardware and will void your warranty.

CLEANING THE BOAT



Periodic cleaning is the best way to keep your boat looking like new. Regular washing and waxing keep dirt and build-up from deteriorating the finish. If you keep your boat in showroom-new condition then your personal satisfaction will be higher and the resale value of your boat will be greater.

The boat is made of fiberglass-reinforced plastic resin material that is easy to clean and care for. Several layers of resin material are chemically bonded together to form the hull. The smooth outside surface of the hull is a layer of gel coat resin. The gel coat is a solid color that is only a few millimeters thick.

Beneath the gel coat surface is a series of layers of chemical resin, fiberglass mat and woven roving. It is these layers that give the boat its strength and maintain the hull shape. The boat bottom also uses special core-mat material for its strength-to-weight and superior marine performance.

Even though MasterCraft has carefully crafted boats from resilient materials, it is still the responsibility of the boat owner to perform regular and routine cleaning maintenance to ensure that the boat exterior, interior and components retain both their appearance and strength.

Hull

When washing the boat, use a mild detergent, such as Dawn or Ivory dish soap, or similar commercially-produced detergent, and warm water solution. **DO NOT** use abrasive cleaners, solvents, ammonia or chlorine, as these will damage the gel coat surface. Under extreme conditions, special cleaners may be used to remove marine growth from the hull. (See an authorized MasterCraft service department for further instructions.)

Upholstery

While the vinyl is made to withstand the elements, it is important to care for vinyl by keeping it clean at all times. Many substances may stain the vinyl if left untreated over a period of time. Remember to remove any contaminant and clean vinyl immediately.

Regular washing with mild detergent (see attached information) and warm water or vinyl cleaners is sufficient to keep the cushion and vinyl coverings in good condition. Do not soak the cushion, and dry thoroughly after washing to prevent mildew accumulations when the boat is covered. Spray the cushions with a mildew repellent and prop them up in the boat when it is covered to take advantage of air circulation.

MasterCraft vinyl is made to withstand the effects of sun, heat, acid rain and soiling, under normal conditions, but this does not preclude the cleaning requirements. Please consult the following cleaning recommendations before cleaning your upholstery.

Certain household cleaners, powdered abrasives, steel wool, and industrial cleaners may cause damage and discoloration, and are not recommended for use. Dry cleaning fluids and lacquer solvents should not be used as they will remove the printed pattern and gloss. Waxes are not recommended, as many contain dyes and solvents that can permanently damage the vinyl's protective coating.

In some instances, consumers have reported the appearance of a pink stain on vinyl that is resistant to various cleaning methods. Although there can be other causes for pink staining in vinyls, most pink stains are caused by dyes produced by micro-organisms. These dyes are metabolic products of the micro-organisms, otherwise known as a form of fungi.

It is virtually impossible for consumers to avoid these micro-organisms as they exist in the atmosphere, which are more prevalent in high-humidity areas. Rain cleanses the air, with the result being that the micro-organisms are deposited on items such as marine vinyl.

While the vinyl is treated to resist the growth of micro-organisms (meaning the vinyl is not a food source), the stain results from failure to properly clean and maintain the vinyl. This means that after use, the upholstery must be cleaned with a soft brush and warm soapy water, followed by a thorough rinse with clean water.

This situation is worsened if the boat is stored without proper ventilation or if the boat cover is put on while the vinyl is still wet, creating a situation in which all forms of fungi (mold and mildew) thrive.

Failure to follow these instructions in the proper care of upholstery may cause your warranty to be voided!

The cleaning table presented in this section is offered only as a suggestion and as an aid in attempting to deal with stains. We do not guarantee that the cleaning methods will work. Stains from any external source are unlikely to be covered by warranty.

Carpet

Occasionally washing with mild detergent and warm water or household carpet cleaners will help keep the carpet clean. Thoroughly hose the detergent out of the carpet and into the bilge. (This is a good time to clean the bilge also.) Allow the boat to remain uncovered to air dry for several days to prevent any mildew or odor caused by moisture.

Teak Wood

Full teak platforms:

If shoes are worn when walking on the teak, they should be proper boating shoes. Black-soled shoes are likely to scuff the surface, resulting in marks that may be difficult to remove or even leave permanent marks that are not covered under warranty.

Regular cleaning and oiling of teak wood will maintain its original appearance. Unprotected wood will turn gray and could split or separate. If this happens it may void the warranty.

New teak platforms have been sealed and finished with an oil-based, wood preservative by the manufacturer. Platforms will keep the new look and last for many, many years if properly maintained. For best results re-oil the platform and allow it to dry before the first use. If the boat spends a lot of long weekends on the lake with the swim platform in the water or if the platform sits uncovered in the sun, it

should be oiled one or two times a month during the first season; then as needed after that. The platform should be covered when not in use or when stored for the winter.

Many products such as boiled linseed oil, tung oil, teak oil and other outdoor wood preservatives can be found at marinas, paint stores or home improvement stores. Some oils such as linseed oil should be thinned with a thinner like mineral spirits before use. (70 percent oil-30 percent thinner.)

When oiling a platform, apply a coat of oil with a wet cloth, work into the seams, end grain and edges. Allow the oil to set approximately 15 minutes and then wipe off the excess oil with a dry cloth. **Do not let the oil dry on the platform in the sun.** Excess oil should be removed with a dry cloth.

Teak inlay platforms:

Wear proper boating shoes. Avoid black-soled shoes as they are likely to scuff the surface, resulting in marks that may be difficult to remove or even leave permanent marks that are not covered under warranty.

The teak inlay platforms feature a specially developed synthetic surface that is durable and long-lasting, provided proper care is given to the inlay surface. This maintenance is different from the full teak platform care.

For the inlay, note:

- Inlays do not require oiling or special sealants.
- Inlays can be maintained by pressure washing.
- Do NOT place hot metals of any kind on the inlay surface. This will create a permanent mark.
- Do NOT use acetone to clean the inlay (or fiberglass

surround).

- Do NOT use oil, bleach, varnish, paint or lacquer.
- Do NOT use a power sander.

Most spills will brush away with soap and water, using a bristled brush and boat deck cleaner. After cleaning, rinse with water and allow to air dry. Sanded areas will appear lighter after sanding and will blend in with the surrounding areas within a day or two. If a chemical stain is allowed to dry and soap and water do not remove it, the surface can be lightly sanded with 60-grit sandpaper. Sand the stain in the same direction as the black caulk seams. Sanded areas will appear lighter after sanding and will blend in with the surrounding areas within a day or two.

If bleach is used on areas surrounding the teak inlay deck, first spray the surface with water to dilute any bleach that may run onto the deck surface. After cleaning the other area(s) with bleach, re-spray both the bleached surfaces and the teak surfaces to rinse away any bleach residue. **Note that bleach should never be applied directly to the teak!**

Fiberglass Swim Platform

The fiberglass swim platform requires the same kind of regular—and gentle—cleaning that the rest of the boat needs. After cleaning off any environmental debris, wash with mild soap and warm water. Avoid the use of ArmorAll or similar types of rubber-shine products as these will speed the decay of the rubber rather than protecting it.

Windshield

In cleaning tempered glass windshields, the normal glass cleaners (from spray bottles or aerosol cans) work best. While the glass is very strong, it can be scratched if anything abrasive is used. Harsh chemicals or solvents should be avoided because they may affect the vinyl gaskets or powder-coated finish on the extrusions.

More care should be taken when cleaning the clear Eisenglass curtains, which are an option on some boat models. Eisenglass curtains are usually made with clear vinyl sheeting, which is much softer and more prone to scratching and hazing than the windshield glass is, only soft cloths and mild detergents should be used.



All teak platform



Teak inlay platform



Fiberglass platform

Canvas Covers

The material used in constructing Bimini tops and boat covers is made from 100 percent solution-dyed polyester fiber with a urethane coating to provide excellent water repellency and mildew resistance. This design allows the material to be easily maintained. By following a few simple care and cleaning steps, the fabric will continue to look good and maintain its fine qualities for seasons to come.

Important Background Information

Because the fabrics are woven, they are breathable. It's also important to know that these fabrics are treated with a fluorocarbon finish, which enhances water repellency. This finish requires replenishment after vigorous cleaning.

Polyester fabric will not support the growth of mildew. Mold and mildew need something on which to grow and polyester fabric is not a desirable substance for such growth. Dirt or dust on the fabric, however, is a perfect source for mildew growth, which makes regular cleaning of the fabric important.

There is no set time for when the fabric should be cleaned, and the local environment has a great deal to do with determining cleaning frequency. Cleaning is required less frequently in a dry environment than in a humid one where heavy foliage exists.

The material has an applied finish that deters mold and mildew growth, but it does not make it mold-proof. Keeping the fabric free of dirt and foreign substances is important in deterring mold growth.



Cleaning

One of the best ways to keep the material looking fresh and new, and to delay the need for deep or vigorous cleaning, is to hose off fabrics with clear water on at least a monthly basis with clean water. This practice will help prevent dirt from becoming deeply embedded in the fabric, and it will eliminate the need for more frequent and more vigorous cleanings.

In most environments, a thorough cleaning will be needed approximately every two (2) years.

The fabric can be cleaned while still in the boat. When cleaning, it is important to observe the following:

- Always use a natural soap—never detergent.
- Water should be cold to lukewarm, but never more than 100 degrees.
- Air dry only. Never apply heat to the fabric.

Begin by brushing off loose dirt, and then hose down the material. Prepare a cleaning mixture of water and a mild, natural soap that is free of detergents. Use a soft-bristle brush to clean, allowing the soap to soak in. Rinse thoroughly and allow the fabric to thoroughly air dry.

If stubborn stains persist, you can use a diluted chlorine bleach/soap mixture for spot cleaning of mildew, roof run-off and other similar stains. Please keep in mind that chlorine bleach will not change the color of the fabric, but chlorine bleach will eventually break down the fiber of any fabric. Therefore, this cleaning method should be used as

infrequently as possible.

The cleaning mixture should be mixed as follows:

- Four ounces (one-half cup) of chlorine bleach.
- Two ounces (one-fourth cup) of natural soap.
- One gallon of water.

Clean with a soft-bristle brush and allow the mixture to soak no longer than twenty (20) minutes. Rinse thoroughly and allow to completely air dry. Repeat if necessary.

If the top or boat cover is suitable in size for a washing machine, these steps should be followed:

- Use only natural soaps—no detergent.
- Wash and rinse in cold water.
- Air dry. (Never put the fabric in a dryer.)

As part of the finishing process, the material has been treated with a fluorocarbon finish, which enhances water repellency. This finish is designed to last for several years, but it must be replenished after a thorough cleaning. Based on test results, the manufacturer recommends 303 High Tech Fabric Guard™ as the preferred re-treatment product.

After cleaning and air drying, apply 303 in a thin, even coat. When it has dried, apply a second thin, even coat. These two (2) light coatings are more effective in restoring fabric water resistance than a single heavy coating. Keep in mind that 303 High Tech Fabric Guard™ will work only as well as it is applied. This means that the fabric must be free of dirt and detergents or the Fabric Guard will wash away with the dirt particles.

Fabrics should be retreated after thorough cleaning or after five (5) years of use.

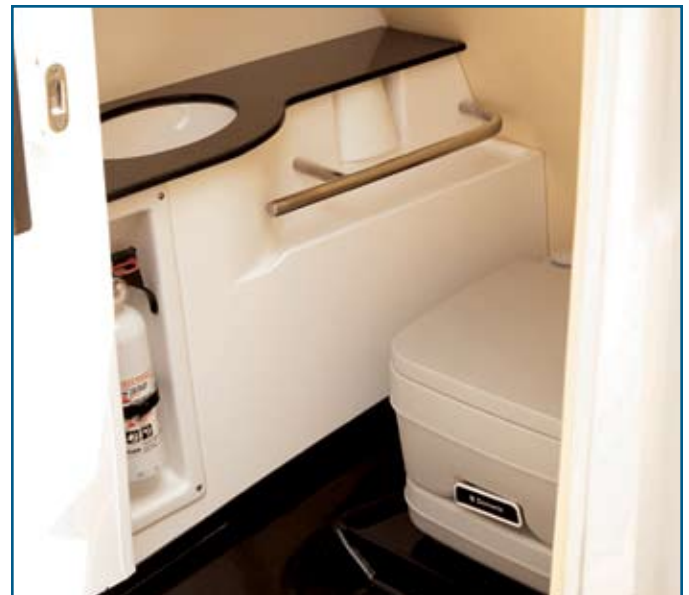

Enclosed Head

An option on some models is the enclosed, portable head. This convenience should be emptied on-shore within an acceptable holding tank, septic system or sewer. It should never be emptied within the boating body of water or on-shore, except in an approved receptacle!

The head should be cleaned after each outing. After thoroughly cleaning with a mild detergent, add a neutralizing chemical made especially for portable heads, such as that found in RV centers. The neutralizing chemical will help deal with potential odors that might otherwise be foul.

Slick Boot

The optional Slick Boot should periodically be dismantled, cleaned and the wand thoroughly rinsed. The Slick Boot material can sometimes become gelled, particularly in colder weather.

Acceptable Upholstery Cleaners

MasterCraft Vinyl Dressing
Vinyl Finish Vinyl Cleaner
Dish Soap (such as Dawn or Ivory)
303 High Tech Fabric Guard™

Unacceptable Upholstery Cleaners

409 (it states not for use on vinyl!)

Fantastik
Murphy's Soap
Simple Green
DC Plus
Armorall
Top Kote Sealant
Son of a Gun
Orange 88 Degreaser
Roll Off
Bleach/Baking Soda
Turtle Wax/Tar Remover
APCO
Tannery
Harbor Master

Any product not listed above in the list of Acceptable Upholstery Cleaners!



Do not use any silicone-based protectants because they will extract the plasticizers, leaving the vinyl hard and brittle. (Eventually cracking will occur.)

Certain household cleaners, powdered abrasives, steel wool, and solvent cleaners can cause damage and discoloration and are not recommended. Dry cleaning fluids and lacquer solvents should not be used as they will remove printed pattern and gloss. Do not use bleach as it will deteriorate the thread.

Common Stains	Steps	1	2	3
Chewing Gum		D	A	
Motor Oil		B		
Spray Paint		B		
Mildew or Wet Leaves*		C	B	A
Yellow Mustard		A	B	C
Oil-Base Paint		D	B	
Suntan Lotion*		A	B	
Tar/Asphalt		D	B	
Lipstick		A	B	
Latex Paint		A	B	
Crayon		D	B	
Ketchup		A	B	
Grease		D	B	
Ballpoint Ink*		E	B	A
Household Soil		A	B	
Permanent Marker*		E	B	C
Coffee, Tea, Chocolate		B		

DO NOT USE 409 CLEANER OR SILICONE-BASED PRODUCTS!!!

A = Medium-soft brush; warm soapy water/rinse/dry.

B = Vinyl finish cleaner.

C = One (1) tablespoon ammonia, one-fourth (1/4) cup of hydrogen peroxide, three-fourths (3/4) cup of water/rinse/dry.

D = Wipe or scrape off excess (chill gum with ice).

E = Denatured alcohol/rinse/dry.

*Sun tan lotion, shoe polish, wet leaves and some other products contain dyes that stain permanently.

Vinyl upholstery should be covered when not in use to protect from further sun exposure, tree debris, air pollutants and acid rain.

For storage, vinyl should be cleaned, protected, covered and stored in a dry, well-ventilated area.

MASTERCRAFT BOAT CARE PRODUCTS



At MasterCraft we have made very effort to produce the most environmentally friendly products available for our boat care line. We understand that as lovers of the outdoors, we should do our part to preserve our environment for the next generation of boaters.

MasterCraft All Purpose Cleaner

MasterCraft All Purpose Cleaner safely and effectively removes grease, oil, cosmetics, glue, blood, mildew, soap scum, ink, bird droppings, spider droppings, scuff marks, pet stains, dust, pollen, fingerprints, food, beverages, sea salt residue and more from all marine surfaces above and below deck. (See Cleaning the Boat section of this Owner's Manual also.) MasterCraft All Purpose Cleaner is ideal for cleaning plastics, rubber, metal, fiberglass, stainless steel, railings, steering wheels and coolers. MasterCraft All Purpose Cleaner will leave surfaces clean and restore optimum brilliance.

Part # 559125.

MasterCraft Boat Cleaner & Polish

MasterCraft Boat & PWC Cleaner & Polish is specially formulated to remove dirt, grease, bugs, bird and spider droppings, road grime from towing, and water spots on contact. This detailer requires no water and leaves a showroom shine that protects against sun damage, ozone damage and dirt accumulation in one easy step.

Part #559129.

MasterCraft Vinyl Dressing

MasterCraft Vinyl Dressing is a one-step formula for the restoration and protection of vinyl, rubber, plastics and leather. When dry, MasterCraft Vinyl Dressing leaves a transparent and water-repellent gloss coating that beautifies and restores surfaces. Its UV protection helps to prevent drying and cracking.

Part #559126.

MasterCraft Glass Cleaner

Formulated specifically for marine applications, MasterCraft Glass Cleaner will leave your marine surfaces streak-free and amazingly clear. Won't harm tinted windows or Eisenglass. MasterCraft Glass Cleaner contains no ammonia, and it is fast drying. Use on windshields, mirrors, chrome and more.

Part #559127.

MasterCraft Bilge Cleaner

MasterCraft Bilge Cleaner is specially formulated to dissolve oil, grease, gasoline, diesel fuel, and sludge. MasterCraft Bilge Cleaner will effortlessly remove those tough odor-causing elements that can make a day on the water less enjoyable. Safe for fiberglass, wood and metal boats, and requires no scrubbing.

Part #559124.

MasterCraft Hull Cleaner

MasterCraft Hull Cleaner is the product of choice for the removal of water stains, iron and metal deposits and marine algae from fiberglass boat hulls and bottoms. This non-acid based cleaner is safe for you, your boat and the environment.

Part #559121.

MasterCraft Spray Wax

MasterCraft Spray Wax is a simple way to give your marine craft that showroom shine while gaining the important UV protection that helps to prevent damage from the sun. Simply spray on and buff off to maintain the original

luster and protect your investment.

Part #559123.

MasterCraft Boat Wash & Wax

MasterCraft Boat Wash & Wax is formulated as a premium-grade concentrated boat wash and wax. This super high sudsing formula has superior cleaning and rinsing properties in order to minimize streaking and spotting on cleaned surfaces. It is neutral in pH, and contains no harsh chemicals or phosphates. It will not affect any known finishes including fragile gel coat materials, and leaves a super bright, clear shine after rinsing. Inhibited to prevent corrosion of steel piping and equipment.

Part #559122.

MasterCraft Microfiber Detailing Cloths

MasterCraft Microfiber Detailing Cloths are the product of recent developments in the manufacture and make-up of fine-quality detailing towels. They feature a soft surface that is ideal for high-quality cleaning and detailing. They are perfect for use in drying or polishing your boat, motorcycle, car, or any reflective surface and can absorb up to seven times their dry weight in water. You'll be amazed at how well these cloths work.

Part #559128.

MasterCraft Cleaning & Detailing Kit

The MasterCraft Cleaning & Detailing Kit combines seven different products in a handy reusable bucket. The kit includes MasterCraft All Purpose Cleaner, Glass Cleaner, Boat Wash & Wax, Vinyl Dressing, Boat Cleaner & Polish, Microfibert Detailing Cloths and wash sponge.

Part #559120.



MasterCraft Marine Motor Oil & Filters

In addition to taking care of the visible parts of your boat, you need to think about what you can't see. The life of your marine engine is dependent upon proper lubrication, regardless of its make. That is why we've developed MasterCraft Marine Motor Oil and Filters.

This premium marine motor oil was formulated specifically for MasterCraft to use in high-performance marine engines. The Marine Motor Oil provides high viscosity and film strength for engine protection in high-load applications. MasterCraft Marine Motor Oil is designed to protect against corrosion, wear, oxidation, varnish and sludge deposits. When used as directed, this oil assures compliance with MasterCraft warranty requirements, as do the filters.

MasterCraft Marine Motor Oil and Filters are exclusive products available only through authorized MasterCraft dealerships! MasterCraft Marine Motor Oil Part #81051000, and MasterCraft Oil Filter Part #81501001.

NOTE: The parts order numbers have been provided to aid consumers in placing orders with an authorized MasterCraft dealer. These quality products are available ONLY through an authorized dealer!

SCHEDULED MAINTENANCE SERVICE



Frequency and Scheduled Maintenance

Proper care, maintenance and adjustment will contribute to the peak performance of the MasterCraft boat, while also extending the overall service life and the resale value.

The pages that follow provide instructions on how to accomplish the required checks, inspections and services listed. An authorized MasterCraft service department is the best source for proper maintenance.

Note: The engine and drive train require scheduled maintenance checks and services in addition to the boat's other maintenance requirements. Read and understand the engine owner's manual that has been provided, and follow the maintenance schedule to ensure proper operation and quality service over the life of the boat and drive train. Failure to follow the maintenance requirements and instructions listed in this and all other manuals may result in damage to the components, systems and equipment of the boat, which resulting damage would not be covered by warranty! Safety issues are also directly impacted by proper maintenance!

The following definitions apply to maintenance:

Check—Verify the operational readiness by physical measurement, i.e., measuring the oil level with the dipstick gauge or alignment with a feeler gauge.

Inspect—Determine the operational readiness by examination, i.e., by sight, sound or feel.

Change—Tasks required periodically to keep the boat in proper operating condition, i.e., drain, replenish or service.

New Boat Break-In

Note: MasterCraft recommends the following functions be performed by authorized MasterCraft technicians at an authorized MasterCraft dealer.

- Lubricate the engine starter drive gear and shaft. (See *Quarterly Maintenance* also.)
- Check the alignment of the propeller shaft. (See *Annual Maintenance* also.)
- Have an authorized MasterCraft service department change the fuel filter after the first fifty (50) hours of operation, and then again at one hundred (100) hours for Indmar engines. The fuel filter should be changed annually even if less than one hundred (100) hours are run during the previous season. The Volkswagen diesel engine requires oil and filter changes every two hundred (200) hours, or annually, whichever comes first.

Before Each Use

Before the engine has been started:

- Review the engine manual and trailer manual before each outing.
- Review the *Safety Checks and Services* section of this Owner's Manual. There are important functions that must be followed before, during and after every outing, without fail!
- Inspect the raw water intake water strainer for blockage. If there is blockage, also check the transmission cooler (where equipped).
- For boats operating in salt water, check and clean as necessary the seacock strainer.
- Check the cooling system level (fresh water cooling-equipped boats only). See the engine owner's manual for details.
- Inspect the battery connections and hold-downs.
- Inspect the drive train for loose or missing hardware.
- Inspect the throttle and shift cables for kinks, wear and interference with other components.
- Inspect the propeller shaft log for excessive water entry.
- Inspect the fuel system lines and connections for leaks.
- Inspect the exhaust system for leaks.

As you start the engine:

- Check that the voltmeter registers a fully charged battery.

After Each Use

- Refer to the *Cleaning the Boat* and *Corrosion Prevention* sections of this Owner's Manual for guidance on a thorough approach to maintenance. Also pay attention to the information provided regarding the maintenance of teak platforms and accessories because the wood requires periodic maintenance as well.
- Boats equipped with an optional flushing system for use in salt water or brackish water should operate the flushing system.

Quarterly (Every Fifty [50] Hours)

Note: MasterCraft recommends that the following functions be performed by authorized MasterCraft technicians at an authorized MasterCraft dealer.

Before the engine has been started or after it has cooled:

- Lubricate the engine starter gear and shaft.
- Check the safety equipment.

Annually (Every One Hundred [100] Hours)

Note: MasterCraft recommends that the following be performed by authorized MasterCraft technicians at an authorized MasterCraft dealer.

Before the engine has been started or after it has cooled:

- Replace the fuel filter (to be performed by an authorized MasterCraft technician only).
- Check the propeller shaft coupler alignment.
- Lubricate the steering system.
- Lubricate the throttle and shift cables.
- Check the engine mounts.
- Inspect the complete fuel system for leakage.
- Check the fire extinguisher and suppression units on-board.

Details follow in the next few sections.

MasterCraft recommends that many of these functions be performed by authorized MasterCraft technicians at an authorized MasterCraft dealer!

SCHEDULED MAINTENANCE

Before Each Use (Prior to Starting the Engine)

Review the *Safety Checks and Services* section of this Owner's Manual. There are important functions that must be followed before, during and after every outing, without fail! The *Safety Checks and Services* notes that all drain plugs must be reinstalled prior to operating the boat!



Inspect Seacock Strainer (where equipped)

Because a clogged seacock strainer puts undue strain on the engine(s), the strainer should be checked prior to starting the boat. Boats with closed cooling systems are not equipped with this. The seacock strainer is standard on boats built for operation in salt water.

Step 1: Remove the plastic wing nut on top of the strainer. Lift the cover.

Step 2: Remove the filter and inspect for debris. Manually clean the strainer.

Step 3: Return the filter in place and recover. Tighten the wing nut, but do not over-tighten as it may eventually strip the threads holding the wing nut in place.



Inspect the Battery Connections and Hold-Downs

Because poor connections or hold-downs may result in erroneous voltmeter readings, MasterCraft recommends doing this before starting the boat.

Step 1: Ensure the engine is OFF and the engine safety starting switch disconnected. **Be certain that the throttle/shift control lever is in neutral.** Locate the battery. Batteries are placed in a variety of locations, depending on the model. Check under the observer seat or behind the rear seat.

Step 2: Check that the battery post connections are clean and tight. If not:

- Loosen and remove the negative terminal connection first. Be careful not to touch the positive terminal with the wrench.
- Loosen and remove the positive terminal connection.
- Remove the battery hold-downs and remove the battery from the boat.
- Clean corrosion from the battery posts with a battery terminal cleaner.
- Clean the battery with a water-and-baking-soda solution. Use care to avoid allowing the solution to enter the battery vents. Rinse the battery with fresh water.



Battery electrolyte fluid is dangerous. It contains sulfuric acid, which is poisonous, corrosive and caustic. If electrolyte fluid is spilled or placed on any part of the human body, immediately flush the area with large amounts of clean water and immediately seek medical attention.

- Use a battery terminal cleaning brush to remove corrosion from the inside of the battery terminals. Clean the terminals with a water-and-baking-soda solution and rinse with fresh water.
- Check the battery box that normally holds the battery in place to determine whether there is evidence of battery fluid inside it. Battery fluids are corrosive and can cause permanent damage to the battery box. If fluid is evident, wash out the box with the water-and-baking-soda solution that is used in cleaning the terminals. Rinse with fresh water and dry with a cloth.
- Reconnect the positive terminal first, then the negative. Tighten the terminals. Coat both terminals completely with a thin covering of marine grease. Be sure that the rubber boot covers the positive terminal completely.

Note: The boat's engine is designed to work with the standard electronics installed in the boat. Adding other electrical components or accessories can change the way the fuel injection controls the engine or the overall electrical system functions. Before adding electrical equipment, consult an authorized MasterCraft dealer's service department. Otherwise, the engine may not perform properly.



Add-on equipment may adversely affect the alternator output or overload the electrical system. Such damage may not be covered by the warranty.

If a replacement battery is required, be certain to select a marine battery with at least seven-hundred-fifty (750) cold-cranking-amps at zero degrees (0°) Fahrenheit. Before disconnecting the battery, make sure the ignition key and all accessories are in the OFF position. Also remember to re-attach the cables in the proper order, with the negative cable connected to the negative [-] post and the positive cable connected to the positive [+] post.



When charging, batteries generate small amounts of dangerous hydrogen gas. This gas is highly explosive. Keep all sparks, flames and smoking well away from the area. Failure to follow instructions when charging a battery may cause an electrical charge or even an explosion of the battery, which could result in death or serious injury.

MasterCraft recommends the use of a spiral-cell type battery, such as the Optima brand. These batteries exceed other batteries in holding and extending a charge.



Inspect the Throttle and Shift Cables for Kinks, Wear and Interference (RTP-1 and Twin MCX Installations Only)



Some engine parts become very hot during operation. This inspection must be completed while the engine is cool to prevent burns to your skin. Perform this task before starting the boat.

- Step 1: Ensure the engine is OFF and the engine safety starting switch disconnected. **Be certain that the throttle/shift control lever is in neutral.**
- Step 2: Open the engine compartment and locate the throttle and shift cables. Follow each cable back under the floorboards and feel for any kinks and wear on the outer jacket. Any sign of cable damage is cause for replacement. See your authorized MasterCraft dealer's service department if you notice any cable damage.



Inspect the Fuel System for Leaks

This function should be performed prior to starting the engine; and then again after about three (3)-to-five (5) minutes to determine whether any leaks are apparent.

Step 1: First ensure the engine is OFF and the engine safety starting switch is disconnected. **Be certain that the throttle/shift control lever is in neutral.** The engine must be cool.



Gasoline is highly flammable and its vapors may ignite, resulting in fire or explosion. Be sure to keep all sparks and flames away from the area while inspecting the boat's fuel system.

- Step 2: Open the engine compartment and visually check as much of the fuel system from the tank to the engine as you can see. If the odor of gasoline is strong or if you see visual evidence of fuel outside the system, cease all operations and take the boat immediately to an authorized MasterCraft dealer's service department to determine the source of the leak. The leak must be repaired before the engine is restarted. Because the lines on late model MasterCraft boats are pressurized, they can be disconnected and/or removed

ONLY by using specialized tools that are not available to the public.



The engine box serves as a machinery guard. The engine must be OFF whenever the box is open. Clothing for body parts can get caught in moving parts, causing death or serious injury. Keep away from moving parts!

This is important! Fuel leakage can lead to a build-up of potentially explosive fumes within the engine compartment. DO NOT IGNORE OR OVERLOOK THIS INSPECTION AND REPAIR AS NECESSARY!



Inspect the Exhaust System for Leaks

This function should be performed prior to starting the engine; and then again after about three (3)-to-five (5) minutes to determine whether any leaks are apparent.

- Step 1: First ensure that the engine is OFF and that the engine safety starting switch is disconnected. **Be certain that the throttle/shift control lever is in neutral.** The engine must be cool.



The engine box serves as a machinery guard. The engine must be OFF whenever the box is open. Clothing or body parts can get caught in moving parts, causing death or serious injury. Keep away from moving parts.

- Step 2: Open the engine compartment and visually check the exhaust system from the engine to the transom for any obvious damage to exhaust lines or the muffler.
- Step 3: If leakage is apparent, tighten the hose clamps, being careful to avoid crimping the hose. If the leakage is significant, or is occurring at a location other than the joints (such as a split in a hose), see your authorized MasterCraft dealer's service department for parts and service. This is important! **Exhaust fumes can cause illness or impairment, including carbon monoxide poisoning. Equally important to consider, leakage can lead to a build-up of potentially explosive fumes within the engine compartment. DO NOT IGNORE OR OVERLOOK THIS INSPECTION! REPAIR AS NECESSARY!**

Before Each Use (After Starting the Engine)

Check That the Battery Is Fully Charged

As the boat is started, check all gauges, but pay particular attention to the voltmeter.



While starting the engine, check that the voltmeter reads between 12.4 and 14.5 volts. An erratic reading may be a sign of low voltage. The voltmeter is the best indication of the state of your battery. However, it is not fool-proof. While the reading may indicate that the battery is producing current, if during a previous operation you had reason to suspect a problem with your battery, check with an authorized MasterCraft dealer's service department.

Current models are equipped with a low-voltage battery alarm. In the event that the stereo has been functioning when the boat engine is OFF, the voltage drain on the battery may result in difficulties re-starting the boat. To avoid this situation, when the voltage level falls to 11.5 volts, the system will shut off the stereo system and sound an alarm for a period of two (2) minutes to allow the operator time to turn the ignition key ON and start the engine. Doing so will allow the engine's alternator to recharge the battery.

Charge dead batteries with a battery charger before attempting to start the engine. (Some MasterCraft models offer an optional battery charger; but never jump-start the battery.) **Jump-starting from another boat or battery is dangerous!** Charging a dead battery from an engine will put undue stress on the alternator, which may cause it to fail.



When charging, batteries generate small amounts of dangerous hydrogen gas. This gas is highly explosive. Keep all sparks, flames and smoking well away from the area. Failure to follow instructions when charging a battery may cause an electrical charge or even an explosion of the battery, which could cause death or serious injury.



Crossing cables or jumper cables may result in damage to the electrical components due to incorrect battery connections. Such damages may not be covered by your warranty.



Inspect the Propeller Shaft Log for Water Entry

After approximately three (3)-to-five (5) minutes of boat operation in the water, shut off the engine and open the engine compartment. Be careful to avoid burns from contact with hot engine parts. The boat is equipped with a dripless shaft log

and if it is showing any signs of dripping, the boat must be taken to an authorized MasterCraft dealer's service department for correction.



The engine box serves as a machinery guard. The engine must be OFF whenever the box is open. Clothing or body parts can get caught in moving parts, causing death or serious injury. Keep away from moving parts!



Attention must be paid to any leakage occurring in the propeller shaft log area. Water intrusion into the transmission, which can happen if excessive leakage is occurring may cause serious damage. Such damage may not be covered by the warranty.

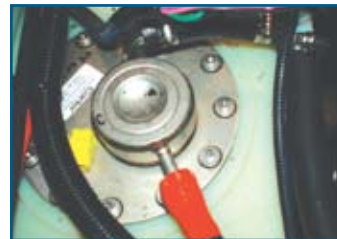

Inspect the Fuel System for Leaks

This function should be performed after about three (3)-to-five (5) minutes of running the engine to determine whether any leaks are apparent.



The engine box serves as a machinery guard. The engine must be OFF whenever the box is open. Clothing or body parts can get caught in moving parts, causing death or serious injury. Keep away from moving parts!

After three (3)-to-five (5) minutes of operation, shut down the engine and ensure that the engine safety starting switch is disconnected. **Be certain that the throttle/shift control lever is in neutral.** Again, inspect the fuel system as well as possible. If the odor of gasoline is strong or if you see visual evidence of fuel outside the system, cease all operations and take the boat immediately to an authorized MasterCraft dealer's service department to determine the source of the leak. The leak must be repaired before the engine is re-started. Because the lines on late model MasterCraft boats are pressurized, they can be disconnected and/or removed **ONLY** by using specialized tools that are not available to the public.

This is important! Fuel leakage can lead to a build-up of potentially explosive fumes within the engine compartment. DO NOT IGNORE OR OVERLOOK THIS INSPECTION AND REPAIR AS NECESSARY!



Inspect the Exhaust System for Leaks

This function should be performed after about three (3)-to-five (5) minutes to determine whether any leaks are apparent.

Step 1: First ensure that the engine is OFF and that the engine safety starting switch is disconnected. **Be certain that the**

throttle/shift control lever is in neutral. The engine must be cool.



The engine box serves as a machinery guard. The engine must be OFF whenever the box is open. Clothing or body parts can get caught in moving parts, causing death or serious injury. Keep away from moving parts.

- Step 2: Open the engine compartment and visually check the exhaust system from the engine to the transom for any obvious damage to exhaust lines or the muffler.
- Step 3: If leakage is apparent, tighten the hose clamps, being careful to avoid crimping the hose. If the leakage is significant, or is occurring at a location other than the joints (such as a split in a hose), see your authorized MasterCraft dealer's service department for parts and service. This is important! **Exhaust fumes can cause illness or impairment, including carbon monoxide poisoning. Equally important to consider, leakage can lead to a build-up of potentially explosive fumes within the engine compartment. DO NOT IGNORE OR OVERLOOK THIS INSPECTION! REPAIR AS NECESSARY!**

After Each Use

General Cleaning and Storage

Refer to the *Corrosion Prevention* and *Cleaning the Boat* sections of this Owner's Manual. After each outing, the boat should receive a general cleaning and drying prior to being stored. Even if the boat is kept in a slip, owners/operators should wipe down the interior and should periodically remove the boat from the water for a general cleaning.

Inspections

As noted in the Before Each Use section, some functions there need to be performed following use of the boat, such as checking the intake strainer or seacock strainer if evidence has shown that debris collects during the outing. Wet debris is often easier to remove.

Quarterly (Every Fifty [50] Hours)

MasterCraft recommends that your quarterly—or fifty (50) hour—maintenance requirements be performed by an authorized MasterCraft dealer. The staff there has the proper equipment and technical training to best meet your service needs.



Lubricate the Engine Starter Gear and Shaft

Some engine parts become very hot during operation. This maintenance must be completed while the engine is cool to prevent burns to your skin. Perform this task before starting the boat.

- Step 1: Ensure the engine is OFF and the engine safety starting switch is disconnected. **Be certain that the throttle/shift control lever is in neutral. The engine must be cool.**
- Step 2: Disconnect the positive (+) battery terminal.
- Step 3: Open the engine cover and locate the starter on the lower starboard side of the engine.
- Step 4: Disconnect the starter and carefully remove it.
- Step 5: Lubricate the starter bendix with a light coating of waterproof grease or white lithium grease.
- Step 6: Return the starter to the engine and reconnect. After closing the engine compartment, reconnect the positive (+) battery terminal.

MasterCraft recommends that your quarterly—or fifty (50) hour—maintenance requirements be performed by an authorized MasterCraft dealer. The staff there has the proper equipment and technical training to best meet your service needs.

Annually (Every One Hundred [100] Hours)

MasterCraft recommends that your annual—or one hundred (100) hour—maintenance requirements be performed by an authorized MasterCraft dealer. The staff there has the proper equipment and technical training to best meet your service needs.

Annual Maintenance

Some boat owners choose to personally execute some maintenance procedures on their boats. MasterCraft has provided information on several procedures. For safety reasons, a few must be performed by authorized MasterCraft service technicians only, such as anything involving checks and repairs on the fuel line, which is under pressure.

These matters must be addressed on a regular basis, at one hundred (100) hours or annually, whichever comes first, and these procedures are in addition to seasonal preparation and winterization (see Storage and Winterization section for additional details). All of these issues are extremely important to continued boating pleasure, as well as long life for the boat, and the critical matter of safety.

Even if the annual maintenance work is completed by an authorized MasterCraft service technician, boat owners and operators should still review this section and ensure that they have some understanding of what is necessary to keep the boat in top condition.

MasterCraft recommends that your annual—or one hundred (100) hour—maintenance requirements be performed by an authorized MasterCraft dealer. The staff there has the proper equipment and technical training to best meet your service needs.



Check the Engine Mounts



Some engine parts become very hot during operation. This inspection must be completed while the engine is cool to prevent burns to your skin. Perform this task before starting the boat.

- Step 1: Ensure the engine is OFF and disconnect the engine safety starting switch. **Be sure that the throttle/shift control lever is in neutral.** The engine must be cool.
- Step 2: Open the engine box and locate the four (4) motor mounts.
- Step 3: Check the tightness of the mounting hardware and adjustment lock-nuts. Tighten any loose hardware securely.



Check the Propeller Shaft Coupling Alignment

Later-model MasterCraft boats are equipped with a dripless propeller shaft log. If it is showing signs of drips, it must be corrected by an authorized MasterCraft dealer's service technician.



Inspect the Exhaust Flaps for Damage

Step 1: Ensure the engine is OFF and disconnect the engine safety starting switch. **Be sure that the throttle/shift control lever is in neutral.**

Step 2: Inspect the exhaust flap hinge for signs of deterioration. Replace the flap if necessary.



Lubricate the Steering System

Because this process should be completed while all movable components of the drive train are NOT in motion, MasterCraft recommends this be done while the boat is out of the water.

- Step 1: Ensure the engine is OFF and disconnect the engine safety starting switch. Be sure that the throttle/shift control lever is in neutral. The engine must be cool.
- Step 2: Remove the access panel in the rear trunk compartment



in direct drive boats. In V-drive engines the steering is located in the engine compartment, beneath the engine.

Step 3: Turn the steering wheel so that the maximum amount of steering cable is seen.

Step 4: Use solvent to clean old lubricant from the cable end, pivot and rudder shaft.

Step 5: Spread a generous amount of white lithium grease over the cable end. Work the steering wheel back and forth and re-apply grease if necessary.

Step 6: Using the flexible end of a grease gun, give two (2) full shots of white lithium grease to the two (2) grease fittings: one on the rudder shaft, and one on the pivot. Clean up any old grease purged from the areas.

Step 7: Rotate the steering wheel back and forth several times to work the lubricant in.

Step 8: Re-install the access panel.



Lubricate the Shift and Throttle System

Because this process should be completed while all movable components of the drive train are NOT in motion, MasterCraft recommends this be done while the boat is out of the water.

Step 1: Ensure the engine is OFF and disconnect the engine safety starting switch. **Be sure that the throttle/shift control lever is in neutral.** The engine must be cool.

Step 2: Open the engine box and locate the shift and throttle cable ends.

Step 3: Shift to full-throttle-forward.

Step 4: Lubricate the cable ends and connections with a coating of waterproof marine multi-purpose grease.

Step 5: Lubricate the pivots and linkages with a light grease.

Step 6: Shift the control lever from full-throttle-forward to full-throttle-reverse several times to work the lubricant in.



Check the Ballast Pump Impeller

This applies only to boats equipped with some type of ballast system. The number of ballast pumps varies from system to system. Authorized MasterCraft dealers can provide guidance to locate any and all pumps.

Step 1: Remove two (2) of the cover screws and retain the screws for the reinstallation process. Swing the cover out of the way to allow access to the impeller location.

Step 2: Using needle-nose pliers, pull the old impeller out of the casing.

Step 3: Install a new impeller. (It is intentionally larger than the case. While gently squeezing it in, ensure that the paddle wheels angle in the same direction—counterclockwise—all the way around.)

Step 4: Slide the plate back into place. No silicone is necessary. Due to the built-in gasket, tightening the screws should prevent leakage.



Inspect the Complete Fuel System for Leakage

Although the boat engine is similar to an automobile engine, the engine compartment differs substantially. The underside of an automobile engine compartment is totally open to the atmosphere.

This allows complete air circulation and ventilation. A boat engine is housed in a closed compartment, the underside of which is the bottom (hull) of the boat.

The enclosed engine compartment limits the ventilation of gasoline and oil fumes. Because confined gasoline vapors mixed with a little air can form an explosive atmosphere, it is important to be especially vigilant in performing the following two (2) operations:

- Step 1: Inspect the boat bilge area under the engine for the evidence of oil and gasoline—or any gasoline odor. This inspection should take place the first time the boat is started each day. Raise the engine cover and visually look at the bilge area under the engine.
- Step 2: Run the bilge blower for at least four (4) minutes to ventilate the bilge area each time before starting the engine.



Gasoline is explosive. If a gasoline odor is present or gasoline is visually observed in the bilge area during inspection, DO NOT START YOUR ENGINE! Remove the ignition key from the ignition switch and call an authorized MasterCraft dealer for service.

Note: If there is evidence of loose fuel fittings, deteriorated lines or other problems associated with the fuel system, call an authorized MasterCraft dealer. Fuel system service on later-model MasterCraft boats requires special service tools and special training. Due to the potential for serious consequences when errors occur in servicing the fuel system, MasterCraft strongly encourages all boat owners and operators to seek professional assistance from an authorized MasterCraft dealer's service department whenever any service or perceived problems occur within the fuel system.



All replaced fuel components must meet United States Coast Guard ("USCG") and American Boat & Yacht Council, Inc. ("ABYC") standards, and must be Underwriter's Laboratory ("UL")-approved. Inferior quality components pose a serious safety threat to you and others, and the use of inferior components may result in serious injury or death. Resulting damage may void the warranty.

Fire Extinguisher and Suppression Units

MasterCraft recommends that boat owners include a check of the fire suppression and extinguisher units during the annual maintenance to be sure that they are always ready for use. Some units may not require annual checks; refer to the signage and labeling on the individual units for further guidance.

STORAGE AND WINTERIZATION

Storage or winter lay-up requires special preparation to prevent damage to the boat. Since winter storage is an annual event, it presents an excellent opportunity to perform the annual maintenance at this time, depending upon the amount of usage. Check with an authorized MasterCraft dealer's service department regarding the boat's needs to determine if this is the appropriate time for annual service.



Without proper preparation, storage for long periods of time (at any time of the year) may cause harm to various components of the boat and drive train. Also, if the boat has been stored in below-freezing temperatures with water inside the bilge or engine cooling system (including the heater or, shower, ballast tanks, wash down tanks, coolers, or any container or area in which water has been located), this condition may result in major damage from freezing, which would not be covered under the warranty.

Refer to the engine owner's manual for guidance regarding storage and winterization of the engine, transmission and components of the drive train.

The following procedures will help avoid most potential types of damage during storage for a period not to exceed five (5) months!

CAUTION

Because of the complexity of preparing a boat for proper winter storage, as well as the possibility of extreme damage to the drive train if a preparation error was made during winterization, MasterCraft recommends scheduling an appointment with an authorized MasterCraft dealer's service department to permit a technician to perform all winterization procedures.

General Preparation

Before starting you will need the following supplies:

- Sta-Bil® Gasoline Stabilizer
- Fuel filter
- Low tack tape

Fuel System Treatment

- Step 1:** If the boat will be placed in storage with fuel (no alcohol in the mix) in the tank, fill the tank with fresh fuel and a sufficient amount of Sta-Bil® gasoline stabilizer to treat the entire tank. Follow instructions on the container.
- Step 2:** If the boat will be placed in storage with fuel that contains alcohol, the fuel tank should be drained as completely as possible, the fuel disposed of properly, and Sta-Bil gasoline stabilizer added to any fuel remaining in the tank. Follow the directions on the container.
- Step 3:** Start the engine and operate at idle until the engine reaches normal operating temperature. (To accomplish this, the boat must be in the water or attached to a water supply using a hose and suitable adapter that will allow an uninterrupted supply of water to the engine. If using a hose and adapter, adjust the faucet to avoid over-cooling the engine at low RPM.) Run the engine for at least fifteen (15) minutes and ensure that the fuel stabilizer enters the engine's fuel system.
- Step 4:** Perform the annual maintenance as described in this Owner's Manual.

General Power Package Preparation

- Step 1:** Lubricate the throttle and shift linkages and cables with multi-purpose grease.
- Step 2:** MasterCraft recommends that batteries be removed from the boat for winter storage. Batteries should be fully charged before being stored in a cool, dry location, protected from the elements and fully re-charged before being re-installed in the boat. **Never store batteries close to heat, spark or flame-producing devices.**
- Step 3:** Leave the engine box cover propped open about two inches (2") to ventilate the engine compartment.



Other Winterization Preparations

- Step 1:** Remove the bilge drain plug immediately after taking the boat out of the water. After a general bow-to-stern washing, raise the bow of the boat higher than the stern to allow as much water as possible to drain from the bilge, while performing other storage preparations.

- Step 2: Thoroughly clean the hull, deck and interior of the boat as soon as it is removed from the water. Cleaning at this time is easier because any marine growth is still wet. Be sure to allow a few days of air drying to prevent mildew that results from trapped moisture. (See the Cleaning section of this Manual.)
- Step 3: Apply a coat of wax to the entire surface of the boat. We suggest MasterCraft Premium Marine Wax for excellent coverage.
- Step 4: If the boat is equipped with a heater, shower or ballast bags/tanks, be sure to disconnect the hoses and drain any remaining water in the lines to avoid freezing. Even small amounts of water in any of these areas can cause significant damage upon freezing and such damage is not covered under the warranty!

Note: Be sure that hoses will not become entangled in the engine V-belt when the engine turns over or the hose and/or the belt will be damaged.

- Step 5: Use duct tape to seal the exhaust flaps to prevent dirt and nesting rodents from entering.
- Step 6: On CSX 265 models equipped with the hot water heater, any water in the tank must be removed to avoid the risk of freezing and damage to the tank. The water pumped into the heater comes from a freshwater holding tank, and it can be left in the water heater when the boat is not in use, EXCEPT during extended periods of storage. As with any part of the boat in which there is water, it must be removed at the time the boat is winterized to avoid freezing that may cause damage to the boat, the holding tank or the water heater. The water is removed by running the shower until all the water has come out or by disconnecting the plumbing fittings in the forward service bay under the helm seats.



- Step 7: On MariStar 255, X-55, 280 and X-80 equipped with heads, clean the tanks with a mild cleaner or warm soapy water that will not harm the finish. Avoid all petroleum-based household cleaners. Store the head dry and clean. Failure to do so may cause unnecessary odors and damage to the tanks, and this is not covered under warranty.
- On CSX 265 models equipped with heads, thoroughly flush the system with fresh water. Empty the holding tank and shut off the water supply to the head, removing the inlet waterline. Do not remove the brass cap on the bottom of the valve. Press the flush lever until all water is drained from the system.
- If using anti-freeze in this head, drain the potable wa-

ter tank and add freshwater anti-freeze to the potable water tank. Flush the anti-freeze and water mixture through the head and into the waste holding tank. Then empty the holding tank. Never use automotive-type anti-freeze in this freshwater system.

- Step 8: MasterCraft recommends the battery or batteries be removed from the boat for winter storage. Batteries should be fully charged before being stored in a cool, dry location, protected from the elements and fully re-charged before being re-installed in the boat.
- Step 9: If the tower will be lowered during storage, be certain that the tower does not rest on the boat upholstery or on any support that rests on the upholstery. The tower or support(s) may leave a permanent imprint on the upholstery. This is not covered under warranty.



- Step 10: Cover the boat with a boat cover or tarp.

Note: If the boat is to be stored outside and subject to accumulations of snow, water and ice, a support should be made for the boat cover so that it will not sag, rip or tear, thereby allowing water to enter the boat. Two-inch diameter PVC plumbing pipe is ideal for this purpose. It is readily available at local hardware stores, and it is easy to work with. Also, its rounded shape will prevent damage to the canvas.



Ballast System Preparations

- Step 1: Attach a hose to the starboard side ballast hose that comes out of the deck at the rear seat.

- Step 2: Place the other end into a gallon of non-toxic, RV-type anti-freeze.
- Step 3: Turn the pump on to empty and pump anti-freeze into the system until anti-freeze comes out of the thru-hull on the side.
- Step 4: Turn the pump on to fill and pump anti-freeze back into the jug.

Re-Activating the Boat After Storage

- Step 1: Remove the duct tape from the exhaust flaps.
- Step 2: Fully charge the battery and install it in the boat, following all safety precautions associated with changing batteries.

IMPORTANT NOTE: Often, batteries that have been stored over winter will require re-charging. If the battery is charged by utilizing a battery charger, use only a three-stage or more battery charger. It is important that the operator never turn a battery charger immediately to “start,” as the sudden jolt of voltage may cause damage to the electrical system, particularly control modules for ballast system. Regardless of whether it is during the re-activation process or at any time, care should also be used in charging the battery.

- Step 3: Follow all instructions for reactivating the drive train as detailed in the engine owner’s manual. NOTE: Due to the complex nature of the reactivation process, MasterCraft recommends having an authorized MasterCraft dealer perform this function.
- Step 4: Ensure that all drain plugs throughout the boat and drive train have been reinstalled to avoid unwanted intrusion of water.
- Step 5: If applicable, reconnect the hoses to your heater or shower.
- Step 6: Check the engine compartment and bilge for signs of nesting animals. Clean as necessary.
- Step 7: Check the entire engine system for fluid, oil and coolant levels. Add as necessary.
- Step 8: Check the entire engine for cracks or leaks caused by freeze damage.
- Step 9: Check all hose clamps for tightness. Install the bilge drain plug and the rear drain plug in boats equipped with certain types of ballast systems.
- Step 10: Grease the propeller shaft taper and install the propeller.
- Step 11: Fully re-charge and re-install the battery or batteries.

- Step 12: Perform the daily maintenance as noted previously in this Owner’s Manual. If it was not done prior to storage, perform the annual maintenance as well.
- Step 13: If the boat is equipped with the optional fresh water cooling system and was drained for storage, fill the system with fresh coolant solution per instructions.
- Step 14: Check the alignment between the output flange on the transmission and the propeller shaft flange. If the maximum feeler gauge that can clip between the flange faces at any point is 0.003”, the unit is properly aligned. If a thicker gauge can be inserted at any point, the engine must be re-adjusted until proper alignment is obtained. This should be performed by an authorized MasterCraft dealer’s service department.
- Step 15: For all models, with the boat in the water, cycle the key ON and then OFF two (2) or three (3) times, allowing ten (10) seconds between key cycles, before cranking the engine. This allows the fuel pump to prime the fuel lines; then start the engine. In the event the engine does not respond, allow a two-minute cool-down period for every thirty (30) seconds of cranking. When the engine fires, keep a close watch over the gauge readings and check for leakage and abnormal noises. Keep speeds low for the first fifteen (15) minutes to allow the engine to reach normal operating temperatures.
- Step 16: In ProStar 197s equipped with ballast bags, when reconnecting the hook-ups, be sure to squeeze the prongs to help slide the connector back on. Dish soap or some similar product will help slide the connects back together. Note that the red ring goes over the raised ring to ensure a working connection.

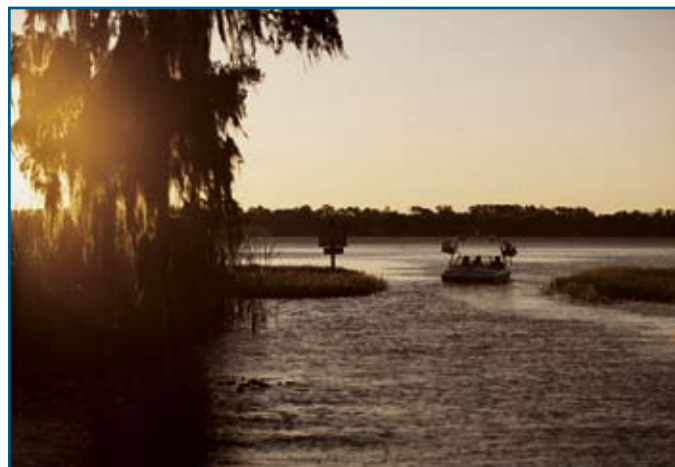

PROPELLER MAINTENANCE

Propeller damage is caused by striking solid objects. If the propeller is not rotating at the time it strikes a solid object, the damage is usually confined to just one blade and may be difficult to see. If the propeller is rotating when it strikes an object, usually the resulting damage can easily be seen on all blades.



Checking/Repairing Propellers

- Step 1:** Ensure the engine is OFF and the emergency safety stop switch is disconnected.
- Step 2:** Clamp a small rule scale to the shaft strut, parallel to the shaft so that the end of the scale is $3/32$ -inches from the leading edge of a propeller blade.
- Step 3:** Rotate the propeller slowly. There should be no more than $3/32$ -inch variance between the blades. If the propeller is damaged, see an authorized MasterCraft dealer.

Changing Propellers

- Step 1:** Ensure the engine is OFF and the engine safety starting switch is disconnected.
- Step 2:** Remove and discard the cotter pin.
- Step 3:** Remove the propeller nut.
- Step 4:** Tap the center hub of the propeller with a rubber mallet to release the propeller. Inspect the shaft and propeller splines for damage.
- Step 5:** Thoroughly clean and apply a light coat of waterproof marine multi-purpose grease to the splined area of the shaft and propeller.
- Step 6:** Align the splines and carefully install the propeller onto the shaft. **DO NOT FORCE THE PROPELLER INTO PLACE.**
- Step 7:** Install the propeller nut and torque to 50-ft-lbs.
- Step 8:** Install a new cotter pin and bend the ends around the shaft to lock the propeller on the shaft.

GUIDE TO TROUBLESHOOTING



The following chart will assist you in finding and correcting minor mechanical and electrical problems with your MasterCraft boat. Engine manuals include troubleshooting suggestions regarding drive train issues.

To correct a problem, first determine what the symptom is. Start with the first cause and eliminate the possibility of each until the problem is corrected. Due to the specialized skill and tools needed to correct major issues, that information has not been discussed below. If a problem is not addressed herein, please contact an authorized MasterCraft dealer's service department.

When experiencing a problem, check the surroundings before shutting down the boat. If a sudden stop would place other boaters in jeopardy, continue on until it is safe to slow or stop to analyze the situation. Always be aware of the surroundings and how actions may impact other boaters!

Throttle/shifting problems.

Corroded cables.
Low transmission oil level.
Sticking transmission shift detent ball.
Kink in cable(s).

Clean and lubricate the cables.
Replenish transmission fluid.
Clean and lubricate the detent ball.
Have authorized MasterCraft technician replace the cable(s).

Steering problems.	Corroded cable. Rudder worn.	Clean and lubricate the cable. See authorized MasterCraft dealer's service department.
Excessive vibration.	Bent strut. Fouled propeller. Damaged propeller. Misaligned propeller shaft coupling. Bent propeller shaft.	Replace the strut. Remove objects from the propeller shaft and rudder. Replace the propeller. Seek proper alignment. See authorized MasterCraft dealer's service department.
Electrical problems.	Open circuit breaker or blown fuse. Loose wiring connections or corrosion. Defective sending unit. Shorted wiring harness. Defective switch or gauge.	Re-set the circuit breaker or replace the fuse. Clean and tighten wiring connections. Replace the sending unit. Have the wiring harness repaired. See authorized MasterCraft dealer's service department.
No speedometer reading.	Defective speedometer. Defective speedometer paddle wheel.	Have the speedometer checked or replaced. Have paddle wheel checked or replaced.
Incorrection speedometer reading.	Improper calibration.	Follow calibration instructions in <i>Instruments and Gauges</i> section of this Manual.
Gauges do not work or the accessory does not work.	Breaker has tripped. Fuse has blown. Low battery. Insufficient battery supply.	Re-set the breaker. Replace the fuse. Check the battery voltage for a loose ground. Replace battery with one that has at least 750CCAs.

WARRANTY



LIMITED WARRANTY STATEMENT

- 1. Disclaimer and Limitation of Implied Warranties.** THE EXPRESS LIMITED WARRANTY SET FORTH HEREIN IS IN LIEU OF ALL OTHER WARRANTIES AND REPRESENTATIONS, EXPRESS OR IMPLIED, AND TO THE MAXIMUM EXTENT PERMITTED BY APPLICABLE LAW, MASTERCRAFT DISCLAIMS, AND THE OWNER HEREBY EXPRESSLY WAIVES, ANY AND ALL OTHER WARRANTIES OR REPRESENTATIONS OF ANY KIND OR NATURE, INCLUDING, BUT NOT LIMITED TO, IMPLIED WARRANTIES OF MERCHANTABILITY AND FITNESS FOR A PARTICULAR PURPOSE, OTHER THAN THOSE WARRANTIES WHICH ARE IMPLIED BY, AND ARE INCAPABLE OF EXCLUSION, RESTRICTION OR MODIFICATION UNDER APPLICABLE LAW. THE TERM OF ANY IMPLIED WARRANTIES THAT CANNOT BE DISCLAIMED UNDER APPLICABLE LAW, INCLUDING, BUT NOT LIMITED TO, IMPLIED WARRANTIES OF MERCHANTABILITY AND FITNESS FOR A PARTICULAR PURPOSE, SHALL BE LIMITED TO THE DURATION OF THE EXPRESS WARRANTY PERIODS APPLICABLE TO THE RESPECTIVE COMPONENTS. SOME STATES DO NOT ALLOW THE EXCLUSION OF IMPLIED WARRANTIES AND/OR DO NOT ALLOW LIMITATIONS ON THE AMOUNT OF TIME AN IMPLIED WARRANTY LASTS, SO THE ABOVE LIMITATIONS MAY NOT APPLY TO YOU. THIS LIMITED WARRANTY GIVES YOU SPECIFIC LEGAL RIGHTS. YOU MAY HAVE OTHER RIGHTS WHICH VARY FROM STATE TO STATE.



- 2. Limited Warranty and Term. MasterCraft Boat Company, LLC.** ("MasterCraft") warrants to the original retail purchaser that the following components of each new boat shall be free from material defects in materials and workmanship to the extent set forth below, under normal use and when operated and maintained in accordance with MasterCraft's instructions, for the period indicated:
- 2.1. Deck, Hull, Liner and Stringers.** From the date of the original retail purchase, the deck, hull, liner and stringer system (collectively, "Structural Components") is warranted for as long as the original purchaser owns the boat.



- 2.2. Gel Coat.** On condition that the consumer has provided maintenance and care as described in the Corrosion and Cleaning the Boat sections of the MasterCraft Owner's Manual, the gel coat, which is applied to all MasterCraft boats at the factory, will be warranted for a period of one (1) year from the date of the original retail purchase of the boat or the initial use of the boat, whichever first occurs, for stress crazing of the gel coat. However, no warranty is provided, and MasterCraft expressly disclaims any warranty for, scratching, discoloration or fading of the gel coat because environmental operating conditions and customer maintenance/care are factors that have a significant effect on the condition and durability of the gel coat.
- 2.3. Other Component Parts (Excluding Engine and Transmission).** MasterCraft provides the following warranty for other component parts of your MasterCraft boat:
- (a) Instrumentation is warranted for three (3) years, except depth finders and Zero Off;
 - (b) marine carpeting for five (5) years;
 - (c) upholstery vinyl material for five (5) years, plus upholstery stitching for one (1) year; and
 - (d) fuel pump assembly for two (2) years provided the customer follows maintenance and care requirements.
- All other components (excluding engine and transmission), including upholstery stitching, are warranted for a period of one (1) year. All warranties are from the date of the original retail purchase of the boat or the initial use of the boat, whichever first occurs.
- 2.4. Trailer and Trailer Component Parts.** The brake calipers are warranted for a period of two (2) years; all other components are warranted for a period of one (1) year from the date of the original retail purchase of the boat or the initial use of the boat, whichever first occurs. See the Trailer Owner's Manual for more details.
- 2.5. Warranty Period.** All express warranties are for the time period set forth in this Section 2, unless a longer warranty period is required by applicable law, in which case such longer warranty period will apply.



3. **Engine and Transmission.** The engines used in MasterCraft boats are supplied by Indmar Products Company, Inc., in Millington, Tennessee (“Indmar”); or Volkswagen Marine Engines in Tampa, Florida (“Volkswagen Marine”). These companies provide a separate warranty of three (3) years from the date of the original retail purchase of the boat or the initial use of the boat, whichever first occurs, for the engine and transmission. A statement of the Indmar Power Train Warranty or the Volkswagen Marine Warranty is provided separately to the original retail purchaser. MasterCraft provides no independent warranty with regard to the engine and transmission; however, the owner may contact MasterCraft at the address or telephone number listed in Section 7 of this Limited Warranty to obtain contact information for making claims or inquiries under the applicable engine manufacturer’s warranty. Contact information for Volkswagen Marine is provided in the warranty statement provided at the time of purchase to the original retail purchaser.

4. **Warranty Conditions, Limitations and Exclusions.** MasterCraft boats are manufactured by trained craftsmen from high-quality materials and components. However, conditions outside MasterCraft’s control require specific limitations on, and exclusions from, coverage under this Limited Warranty. The Limited Warranty on the Structural Components set forth in Section 2 of this Warranty does not cover or include any other components fastened or applied to the hull or deck. This Limited Warranty constitutes the final, complete and exclusive statement of warranty terms, and no other person or entity is authorized to make any other warranties or representations on behalf of MasterCraft. Furthermore, the Limited Warranty set forth in Section 2 (including all subsections) hereof does not cover the following:

- (a) damage caused by misuse, negligence, accident; collision or impact with any object;
- (b) damage caused by any improper alteration or modification to the boat or any of its component parts or accessories, including damage resulting from alteration, modification, repair or replacement in such a way as to increase the cubic-inch capacity or horsepower output of the engine and boat as originally manufactured;
- (c) damage caused by the use of improper or contaminated fuel or fluids;
- (d) damage caused by the use of customer-applied chemicals or accidental spills;
- (e) damage caused by failure to maintain the boat in accordance with the maintenance provisions in the Owner’s

- (f) Manual or improper maintenance of the boat; damage caused by the failure to comply with any recall or request for repair;
- (g) damage resulting from the use of the boat for any racing, speed, commercial competition or performance demonstration;
- (h) damage resulting from use of the boat for rental, commercial or industrial purposes;
- (i) damage to hardware and other components fastened or adhered to the hull, deck or liner;
- (j) damage caused by fire, theft, freezing, vandalism, explosion, lightning, wind, hail storms, flooding or other natural disaster;
- (k) damage to any component parts and accessories not manufactured by MasterCraft, including but not limited to, the engine, drivetrain, transmission, propeller, shift and throttle control levers and cables, pumps, blowers, windshields, canvas, upholstery, tower and accessories, instrumentation and steering systems; however, such items may be warranted by the individual manufacturer, and if possible, MasterCraft will provide the owner with a copy of the manufacturer’s warranty;
- (l) damage caused by use of any non-MasterCraft trailer;
- (m) damage caused by improper support of the boat on davits, hoist system or boat lift of any kind;
- (n) damage to paints, varnishes, gel coat surfaces and colors, chrome-plated or anodized finishes, floor and floor covers and any other surface coatings, as well as damage due to in-water storage without proper barrier coat and bottom paints (NOTE: Although MasterCraft uses the highest-grade gel coat materials, a condition may develop where the bottom of the boat may show signs of discoloration and/or blisters if the boat is left in the water for long periods of time; therefore, a proper barrier coat and bottom paint should be used whenever it is anticipated that the boat will be left in the water for an extended period of time);
- (o) damage to the trailer and its parts or components due to abrasions, rock chips, rust, improper care or maintenance, or use in salt or brackish water; however, the finishes of galvanized trailers, which are designed for use in salt or brackish water, are warranted to be free from damage resulting from use in salt or brackish water for one (1) year from the date of the original retail purchase or the initial use of the trailer, whichever first occurs;
- (p) damage caused by dealer-installed options or accessories;
- (q) damage caused by consumer-installed options or accessories; and/or
- (r) all warranty coverage will expire after ninety (90) days on boats used for commercial purposes.



5. **Limitation of Liability.**

5.1. **Liability Limitation: Exclusion of Consequential**

Damages. This Limited Warranty is for the benefit of the owner and MasterCraft, and shall not create or evidence any right in any third party. THE REPAIR OR REPLACEMENT OF DEFECTIVE COMPONENT PARTS AS PROVIDED UNDER THIS LIMITED WARRANTY IS THE EXCLUSIVE REMEDY OF THE CONSUMER. TO THE MAXIMUM EXTENT PERMITTED BY APPLICABLE LAW, IN NO EVENT SHALL MASTERCRAFT BE LIABLE FOR ANY INCIDENTAL, CONSEQUENTIAL, SPECIAL, INDIRECT, PUNITIVE OR EXEMPLARY DAMAGES OR LOST PROFITS WHATSOEVER ARISING OUT OF THE USE OR INABILITY TO USE THE BOAT OR ANY COMPONENT PART THEREOF, OR FOR ANY BREACH OF THIS LIMITED WARRANTY OR OTHERWISE, EVEN IF MASTERCRAFT HAS BEEN ADVISED OF THE POSSIBILITY OF SUCH DAMAGES OR SUCH DAMAGES COULD REASONABLY HAVE BEEN FORESEEN BY MASTERCRAFT. However, some states do not allow the exclusion or limitation of incidental or consequential damages, so the above limitation or exclusion may not apply to you.

5.2. Purchase Price Limitation. In any event, MasterCraft's entire liability under any provision of this Limited Warranty shall be limited to the repair or replacement of the boat, trailer or component part, or the refund of the purchase price paid by the consumer for the boat, trailer or component part found to be defective within the applicable warranty period. This shall constitute MasterCraft's sole liability and obligation in the event of any claim arising out of its performance or non-performance of any provision of this Limited Warranty. Because some states and jurisdictions do not allow the exclusion or limitation of liability, the above limitations may not apply to you.



trailer, whichever first occurs, as applicable), upon delivery of the warranty transfer card and payment of the applicable warranty transfer fee to MasterCraft. With respect to the Lifetime Limited Warranty (granted only to the original retail purchaser) on the Structural Components set forth in Section 2.1 hereof, if the sale, conveyance or other transfer of the boat by the original retail purchaser to another person or entity occurs within three (3) years of the date of the original retail purchase of the boat by the original retail purchaser, then the Limited Warranty on the Structural Components shall be transferred to the second owner and shall continue in effect for a period of ten (10) years from the date of the original retail purchase of the boat by the original retail purchaser. If the sale, transfer or conveyance of the boat by the original retail purchaser occurs more than three (3) years after the date of the original retail purchase of the boat, then the Limited Warranty on Structural Components (as well as all other warranties) shall be void as of the date of transfer and shall not be transferable to the second owner.

Only one (1) transfer under the provisions of this Section 6 (from the original retail purchaser to the second owner), within the applicable time period, may be made. In the event of a sale or transfer of the boat or trailer by a second owner to a subsequent purchaser, all coverage under this Limited Warranty shall immediately be terminated and the Limited Warranty shall become null and void. No transfer of this Limited Warranty will operate to extend the warranty periods set forth in Section 2 hereof. In order to effectuate the transfer of the Limited Warranty, the original retail purchaser and the new owner must properly fill out the warranty transfer card found in the back of the Owner's Manual and deliver the completed card, together with a check made payable to "MasterCraft Boat Company, LLC." in the amount of the warranty transfer fee, via U.S. Mail, postage prepaid, to MasterCraft at the address shown on the warranty transfer card. The card and check for the warranty transfer must be post-marked within the time period specified above in this Section 6 in order for the warranty transfer from the original retail purchaser to the second owner to be effective.

7. Warranty Claims. In order to maintain warranty service under this Limited Warranty, the owner must return the defective boat or component part to an authorized MasterCraft dealer's service department, or to MasterCraft's factory at the below address, within the applicable warranty period. For questions regarding warranty service or to obtain information regarding warranty service or to obtain information regarding the nearest authorized MasterCraft dealer, please contact MasterCraft at the following address or telephone number:



6. Transfer of Limited Warranty. Upon the first sale, conveyance or other transfer of the boat or trailer by the original retail purchaser, any remaining unexpired Limited Warranty coverage shall be transferred to the second owner and shall remain in effect for the remainder of the applicable warranty period(s) set forth in Sections 2.1, 2.2, 2.3 and 2.4 hereof (which warranty periods begin to run from the date of the original retail purchase of the boat or trailer, or the first use of the boat or



MasterCraft Boat Company, LLC
Attention: Warranty/Customer Service Department
100 Cherokee Cove Drive
Vonore, Tennessee 37885
1-423-884-2221

Subject to the terms of this Limited Warranty, any covered boat or component part with a material defect in materials or workmanship that is returned to an authorized MasterCraft dealer's service department or MasterCraft's factory during the appropriate warranty period will be repaired or replaced, at MasterCraft's sole option, without charge to the owner for parts and labor. This provision is subject to the following terms and conditions:

- (a) MasterCraft shall be obligated only to repair or replace those items that prove defective, in MasterCraft's sole discretion, upon examination by a MasterCraft authorized dealer service department or MasterCraft's own personnel, as applicable;
- (b) MasterCraft warrants its repairs or replacements only for the remainder of the applicable warranty period;
- (c) MasterCraft shall, in its sole discretion, fulfill its obligation to repair or replace any defective item at its factory or authorized service department;
- (d) The owner shall be responsible for all costs associated with the transportation of the boat, towing bills, trailer or component part(s) to the authorized MasterCraft service department and for any return transportation.

8. No Modification of Warranty. No oral or written information, advice or communication of any nature by or from MasterCraft or its representatives, employees, dealers, agents, distributors or suppliers shall create a warranty or in any manner increase or modify the scope of this Limited Warranty in any manner whatsoever.

WARRANTY REGISTRATION AND TRANSFER

For the first purchase of a specific MasterCraft boat, the boat must be registered. You should be aware that under federal law, completion of the registration process is a requirement and should be completed as follows:

1. Dealer must complete the warranty registration at date of sale.
2. Dealer must secure buyer's signature!
3. Dealer must notify MasterCraft, via electronic registration that the boat has been purchased, and all required information must be submitted. As boat owner, you should ensure that the dealer has complied with this requirement. This is the method of providing information that will allow MasterCraft to notify you in case of any mandatory recalls or other issues requiring your attention.

If the MasterCraft boat is subsequently sold by the original purchaser, MasterCraft offers a transferable warranty to the second owner. In accordance with the MasterCraft Limited Warranty, the remaining warranty against structural defects in the hull and deck will be transferred to the new owner when the following has been accomplished and verified within fourteen (14) days of the sale date:

- Receipt of the completed form below.
- Copy of the sales invoice.
- Payment of \$450.



Upon verification, the remaining warranty will transfer, retroactive to the sale date.

Forward form and payment to:
MasterCraft Boat Company, LLC
100 Cherokee Cove Drive
Vonore TN 37885

Warranty Registration Transfer

(forward this copy to MasterCraft)

Boat Serial Number _____

Model No. _____

Engine Make _____

Serial No. _____

Trans. Type _____

Serial No. _____

Please Print

Previous Owner _____

New Owner's Name _____

Street Address _____

City _____

State _____ **Zip Code** _____

Home Phone (_____) _____

Business Phone (_____) _____

Date of Purchase _____

Second Owner's Signature _____

MUST BE SIGNED!

Be sure to enclose payment and a copy of the purchase receipt within fourteen (14) days of the sale date.

SERVICE LOG

As Needed	Date	Date	Date	Date
Replace raw water impeller				
Replace ballast impeller(s)				
Add/change oil filter				
Every 50 Hours	Date	Date	Date	Date
Lubricate starter gear and shaft				
Change engine oil and filter				
Check all safety equipment				
Every 100 Hours	Date	Date	Date	Date
Replace impeller				
Engine tune-up				
Change transmission fluid				
Check engine mounts				
Check prop shaft coupling alignment				
Inspect exhaust flaps				
Lubricate steering system				
Lubricate shift and throttle system				
Check/replace ballast pump impeller				
Inspect complete fuel system				
Change fuel filter				

INDEX



12-Volt Receptacle.....	5-1
190, ProStar	4-1
197, ProStar	4-2
200, MariStar	4-6
214 V-Drive, ProStar	4-4
214, ProStar	4-3
215, MariStar	4-7
220, CSX	4-14
230, MariStar	4-8
235, MariStar	4-9
244, MariStar	4-11
245, MariStar	4-10
265, CSX	4-15
280, MariStar	4-13
Acceptable Upholstery Cleaners	14-4
Accessory Switches	5-1
Aft Light Switch	5-1
After Break-In.....	9-1
After Operation (Safety Checks and Services).....	8-1
After Storage, Re-Activating the Boat.....	18-3
Alarm, Low Voltage Battery	5-6
Alarms, Other	5-7
All Purpose Cleaner	15-1
AM/FM Stereo, CD Player, Remote Control, iPod and MP3 Player Connections	5-1
Anchor and Windlass	6-1
Anchoring	1-7
Annual Inspections.....	17-4
Annual Maintenance	17-4
Attitude Adjustment or Trim Tab Switch.....	5-1
Backlighting Switch, Instrument Panel Gauge	5-6
Ballast Empty/Fill Switches	5-2
Ballast Pump Impeller, Check.....	17-5
Basic Maneuvering.....	11-1
Battery Alarm, Low Voltage.....	5-6
Battery Charger	6-1
Battery Connections & Hold Downs, Inspect.....	17-1
Battery Fully Charged, Check.....	17-2

Battery Operation Switch, Dual Battery	5-3
Before Each Operation (Safety Checks and Services).....	8-1
Before Starting.....	10-1
Bilge Cleaner	15-1
Bilge Pump Switch, Manual & Automatic.....	5-2
Blower Switch.....	5-3
Boarding Platforms, Swim/	6-6
Boat Care Products, MasterCraft.....	15-1
Boat Cleaner and Polish	15-1
Boat Wash & Wax	15-1
Boating Safety.....	1-1
Canvas Covers (Cleaning).....	14-2
Canvas Covers.....	6-2
Care When Fueling, Using.....	7-1
Carpet (Cleaning)	14-1
Catch Box/Livewell/Kill Box	6-5
Cautions, Dangers and Warnings.....	ii
Chartplotter, GPS and.....	6-3
Charts, Nautical.....	1-6
Check Ballast Pump Impeller.....	17-5
Check Battery Full Charged.....	17-2
Check Engine Mounts	17-5
Check Propeller Shaft Coupling Alignment.....	17-5
Chrome, Stainless Steel and.....	13-1
Circuit Breakers	5-3
Cleaner and Polish, Boat.....	15-1
Cleaner, All Purpose.....	15-1
Cleaner, Bilge.....	15-1
Cleaner, Glass.....	15-1
Cleaner, Hull.....	15-1
Cleaners, Acceptable Upholstery	14-4
Cleaners, Unacceptable Upholstery.....	14-4
Cleaning & Detailing Kit	15-2
Cleaning the Boat.....	14-1
Cloths, Microfiber Detailing.....	15-1
Cold Water Survival	1-6
Comfort and Convenience	6-1
Common Sense Approach	2-1
Communications	1-7
Control, Shift/Throttle	5-7
Coolers.....	6-2
Corrosion Prevention	13-1
Corrosion, Galvanic.....	13-1
Corrosion, Salt Water	13-1
Courtesy Lights Switch.....	5-3
Courtesy	11-1
Cradle, Storage	12-1
Crossing	3-1
Cruise Control Gauge	5-3
CSX 220.....	4-14
CSX 265.....	4-15
Dangers, Warnings and Cautions.....	ii
Detailing Cloths, Microfiber.....	15-1

Detailing Kit, Cleaning &.....	15-2
Display Selector Switch	5-3
Docking and Tie-Up.....	11-3
Documentation, Registration, Numbering and	1-4
Dressing, Vinyl	15-1
Dual Battery Operation Switch	5-3
During Operation (Safety Checks and Services)	8-1
Emergencies	11-1
Engine Emergency Safety Stop Switch	5-4
Engine Hatch Switch.....	5-4
Engine Mounts, Check.....	17-5
Engine Oil Pressure Gauge	5-4
Engine Starter Gear and Shaft, Lubricate.....	17-4
Engine Synchronizing Switch.....	5-4
Equipment, Recommended	1-4
Equipment, Required	1-1
Equipment, Safety	1-1
Exhaust Flaps, Inspect.....	17-5
Exhaust System for Leaks, Inspect.....	17-2
Exhaust System for Leaks, Inspect.....	17-3
Fiberglass Swim Platform (Cleaning)	14-2
Filters, Marine Motor Oil &	15-2
Fire Extinguisher and Suppression Units	17-6
Fire Extinguishers.....	1-2
Fire Port	1-3
Fire Suppression and Extinguishing (Others).....	1-2
Fire Suppression and Extinguishing (V-Drives)	1-2
Fire Suppression and Extinguishing	6-2
First Hours of Operation.....	9-1
First Time Operation.....	11-1
Fishing Vessel Right-of-Way.....	3-2
Float Plan.....	1-6
Fuel Gauge.....	5-5
Fuel System for Leakage, Inspect.....	17-6
Fuel System for Leaks, Inspect	17-2
Fuel System for Leaks, Inspect	17-3
Fuel System Treatment.....	18-1
Fueling, Using Care When	7-1
Fuels Outside U.S. and Canada	7-2
Fuels with Alcohol.....	7-2
Galvanic Corrosion	13-1
Gasoline to Use, What Type.....	7-1
Gauge, Cruise Control.....	5-3
Gauge, Engine Oil Pressure.....	5-4
Gauge, Fuel	5-5
Gauge, Multi-Function	5-6
Gauge, Temperature.....	5-8
Gauge, Video Display	5-9
Gauges and Switches, Instrument.....	5-1
General Cleaning and Storage.....	17-4
General Power Package Preparation (Storage).....	18-1
General Precautions	1-1
General Preparation (Storage and Winterization).....	18-1
General Prudential Rule	3-1
Glass Cleaner	15-1
GPS and Chartplotter	6-3
Guide to Individual Models.....	4-1

Guide to Troubleshooting	20-1
Hatch Switch, Engine	5-4
Head.....	6-3
Head, Enclosed (Cleaning).....	14-3
Heater Switch	5-6
Heater.....	6-4
High Speed Operation	11-2
Horn.....	5-6
Hull (Cleaning).....	14-1
Hull Cleaner	15-1
Hydraulic Steering System	6-4
Hypothermia	1-7



Ignition Key Slot	5-6
Immersion Suits.....	1-7
Impeller, Check Ballast Pump.....	17-5
Inflatable Life Rafts.....	1-7
Inspect Battery Connections & Hold Downs.....	17-1
Inspect Exhaust Flaps	17-5
Inspect Exhaust System for Leaks	17-2
Inspect Exhaust System for Leaks	17-3
Inspect Fuel System for Leakage.....	17-6
Inspect Fuel System for Leaks	17-2
Inspect Fuel System for Leaks	17-3
Inspect Propeller Shaft Log.....	17-3
Inspect Seacock Strainer	17-1
Inspect Throttle & Shift Cables	17-2
Inspections.....	17-4
Instrument Gauges and Switches	5-1
Instrument Panel Gauge Backlighting Switch.....	5-6
Instrument Panels.....	4-16
Key Slot, Ignition.....	5-6
Kill Box/Catch Box/Livewell	6-5
Law Enforcement	1-7
License, Operator's.....	1-4
Lifting Eyes, Using.....	12-1
Lifting Slings, Using.....	12-1
Lifting the Boat	12-1
Light Switch, Aft.....	5-1
Lighting	6-4
Lights Switch, Courtesy	5-3
Lights Switch, Navigation/Anchor.....	5-7

Lights Switch, Tower	5-8
Lights Switch, Underwater	5-8
Limited Warranty Statement	21-1
Livewell/Kill Box/Catch Box	6-5
Loading	11-1
Low Voltage Battery Alarm	5-6
Lubricate Engine Starter Gear and Shaft	17-4
Lubricate Shift and Throttle System.....	17-5
Lubricate Steering System.....	17-5
Maintenance, Propeller	19-1
Maneuvering, Basic	11-1
Manual & Automatic Bilge Pump Switch	5-2
Marine Growth.....	13-1
Marine Motor Oil & Filters.....	15-2
MariStar 200.....	4-6
MariStar 215.....	4-7
MariStar 230.....	4-8
MariStar 235.....	4-9
MariStar 244.....	4-11
MariStar 245.....	4-10
MariStar 280.....	4-13
MasterCraft Boat Care Products	15-1
Measurements.....	4-17
Meeting.....	3-1
Microfiber Detailing Cloths	15-1
Motor Oil & Filters, Marine	15-2
Multi-Function Gauge.....	5-6
Nautical Charts	1-6
Navigation/Anchor Lights Switch	5-7
New Boat Break-In	9-1
Numbering & Documentation, Registration	1-4
Oil Pressure Gauge, Engine.....	5-4
Operating Conditions, Unusual.....	11-2
Operation, First Time	11-1
Operation, High Speed.....	11-2
Operational Hints	11-1
Operator's License	1-4
Operator's Responsibilities.....	1-6
Other Alarms	5-7
Other Special Situations	3-2
Other Winterization Preparations	18-1
Overtaking.....	3-1
Oxygenated Fuels	7-2

Personal Flotation Devices (PFDs).....	1-3
PFD Accessibility	1-3
Plan, Float.....	1-6
Platforms, Swim/Boarding.....	6-6
Polish, Boat Cleaner and.....	15-1
Precautions, General	1-1
Products, MasterCraft Boat Care.....	15-1
Propeller Maintenance	19-1
Propeller Shaft Coupling Alignment, Check	17-5
Propeller Shaft Log, Inspect	17-3
ProStar 190.....	4-1
ProStar 197.....	4-2
ProStar 214V-Drive.....	4-4
ProStar 214.....	4-3

Quarterly Inspections	17-4
-----------------------------	------

Re-Activating the Boat After Storage.....	18-3
Reading Buoys and Other Markings	3-2
Receptacle, 12-Volt	5-1
Recommended Equipment.....	1-4
Refrigeration	6-5
Refrigerator Switch	5-7
Registration and Transfer, Warranty	22-1
Registration, Numbering & Documentation	1-4
Required Equipment.....	1-1
Responsibilities, Operator's	1-6
Rules of the Open Water	3-1
Rules When Encountering Vessels	3-1

Safety Afloat.....	1-4
Safety Checks and Services.....	8-1
Safety Equipment.....	1-1
Safety Knowledge.....	1-1
Safety Stop Switch, Engine Emergency	5-4
Safety, Boating	1-1
Sailing Vessel Right-of-Way	3-2
Salt Water Corrosion.....	13-1
Scheduled Maintenance Service.....	16-1
Scheduled Maintenance	17-1
Seacock Strainer, Inspect	17-1
Seat Heat Switches	5-7
Seat Heaters.....	6-5
Service Log	23-1
Shift and Throttle System, Lubricate	17-5
Shift Cables, Inspect Throttle &.....	17-2
Shift/Throttle Control.....	5-7
Shifting Gears	10-1
Shower and/or Slick Boot Switch.....	5-8
Shower or Wash Down	6-5
Sink Switch.....	5-8
Skiing and Wakeboarding Safety.....	1-5
Slick Boot (Cleaning).....	14-3
Slick Boot Switch, Shower and/or	5-8
Slings, Using Lifting.....	12-1
Sound Producing Devices.....	1-3
Sound Signals.....	3-1
Speedometer	5-8
Spray Wax	15-1



Stainless Steel and Chrome	13-1
Starter Gear and Shaft, Lubricate Engine.....	17-4
Starting and Basic Operation	10-1
Starting the Engine.....	10-1
Starting, Before	10-1
Staying Afloat.....	1-6
Steering and Sailing Rules	3-1
Steering System, Hydraulic.....	6-4
Steering System, Lubricate	17-5
Stereo Equipment	6-6
Stopping.....	10-2
Storage and Winterization	18-1
Storage Cradle.....	12-1
Strainer, Inspect Seacock	17-1
Survival, Cold Water	1-6
Swim/Boarding Platforms	6-6
Switch, Aft Light.....	5-1
Switch, Attitude Adjustment or Trim Tab	5-1
Switch, Blower	5-3
Switch, Courtesy Lights	5-3
Switch, Display Selector	5-3
Switch, Dual Battery Operation	5-3
Switch, Engine Emergency Safety Stop	5-4
Switch, Engine Hatch	5-4
Switch, Engine Synchronizing.....	5-4
Switch, Heater.....	5-6
Switch, Instrument Panel Gauge Backlighting	5-6
Switch, Manual & Automatic Bilge Pump.....	5-2
Switch, Navigation/Anchor Lights.....	5-7
Switch, Refrigerator	5-7
Switch, Shower and/or Slick Boot.....	5-8
Switch, Sink.....	5-8
Switch, Tower Lights	5-8
Switch, Wash Down	5-10
Switches, Accessory.....	5-1
Switches, Ballast Empty/Fill.....	5-2
Switches, Instrument Gauges and.....	5-1
Switches, Seat Heat.....	5-7
Synchronizing Switch, Engine	5-4
Table of Contents	vi
Tables	6-7
Tachometer	5-8
Teak Wood (Cleaning).....	14-1
Temperature Gauge.....	5-8
Throttle & Shift Cables, Inspect	17-2
Throttle Control, Shift/	5-7
Throttle System, Lubricate Shift and.....	17-5
Tie-Up, Docking and.....	11-3
Tower Lights Switch	5-8
Towers	6-7
Transfer, Warranty Registration and.....	22-1
Trim Tab Switch, Attitude Adjustment or	5-1
Troubleshooting, Guide to	20-1
Unacceptable Upholstery Cleaners	14-4
Underwater Lights Switch.....	5-8
Underway.....	10-2
Unusual Operating Conditions	11-2
Upholstery (Cleaning).....	14-1



Upholstery Cleaners, Acceptable	14-4
Upholstery Cleaners, Unacceptable.....	14-4
Using Car When Fueling.....	7-1
Using Lifting Eyes.....	12-1
Using Lifting Slings.....	12-1
Variations in Gauges & Switches	5-10
Video Display Gauge	5-9
Video Screen	6-7
Vinyl Dressing	15-1
Visual Distress Signals	1-3
Volkswagen Diesel Engine (Fuel)	7-2
Voltmeter	5-10
Warning Plates and Labels	1-6
Warnings and Cautions, Dangers	ii
Warranty Registration and Transfer.....	22-1
Warranty Statement, Limited	21-1
Wash & Wax, Boat.....	15-1
Wash Down Switch.....	5-10
Wash Down, Shower or	6-5
Water Heater	6-8
Wax, Boat Wash &	15-1
Wax, Spray	15-1
Weather	1-6
Welcome Aboard	i
What Type of Gasoline to Use.....	7-1
When Boat Is Not Used (Fuel).....	7-2
Windlass, Anchor and.....	6-1
Windshield (Cleaning).....	14-2
Winterization Preparations, Other	18-1
X-1.....	4-5
X-14 V-Drive.....	4-4
X-14	4-3
X-15	4-7
X-2.....	4-6
X-30	4-8
X-35	4-9
X-45	4-10
X-55	4-11
X-7.....	4-2
X80.....	4-13
X-Star	4-12

PROSTAR
MARISTAR
X-SERIES
SALTWATER SERIES

World Headquarters
MasterCraft Boat Company
100 Cherokee Cove Drive
Vonore TN 37885 U.S.A.
423•884•2221
423•884•2295 fax
www.mastercraft.com

